



EUROPEAN MANUFACTURER
of swimming pool dehumidifiers and
heat pumps

DEHUMIDIFIERS

HEAT PUMPS

ACCESSORIES

PRICE LIST 2018



 **MICROWELL**
Committed to Efficiency

valid from: March 01, 2018

v. 01/2018

CONTENT

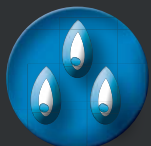

DEHUMIDIFIERS

for swimming pools on the wall, on the floor, behind the wall	DRY 300 PLASTIK	NEW DESIGN	5	36l / 30m ²	
	DRY 300 METAL		6		
	DRY 400 PLASTIK		7		
	ducted	DRY 400 METAL	NEW DESIGN	8	48l / 45m ²
		DRY 500 PLASTIK		9	
		DRY 500 METAL		10	
		DRY 300/400/500 SILVER		11	
		DRY 800/1200 METAL		12	
		DRY 300 DUCT		NEW	
	DRY 400 DUCT	14			
	DRY 500 DUCT	15			
	DRY 800 DUCT	16			
DRY 1200 DUCT	17				
ceiling mounted	DRY SIREN mono		18	67l / 60m ²	
	DRY SIREN due		19	134l / 120m ²	
for galleries	DRY GALLERY		20	34l	
for industry	T40 T90 T120		21	40-120l	
	TE40 TE90 TE120		22		



SWIMMING POOL HEAT PUMPS

HP 1000 COMPACT Omega		24	10.7kW / 40m ³
HP 1100 COMPACT Premium		25	11.3kW / 40m ³
HP 1000 SPLIT Omega		26	10.7kW / 40m ³
HP 1100 SPLIT Premium		27	11.3kW / 40m ³
HP 1400 COMPACT Omega		28	14.1kW / 60m ³
HP 1500 COMPACT Premium		29	14.9kW / 60m ³
HP 1400 SPLIT Omega		30	14.1kW / 60m ³
HP 1500 SPLIT Premium		31	14.9kW / 60m ³
HP 1700 COMPACT		32	17kW / 70m ³
HP 1700 SPLIT		33	
HP 2300 COMPACT Inventor	NEW	34	23kW / 80m ³
HP 2400 COMPACT Premium		35	24.4kW / 80m ³
HP 2300 SPLIT Inventor		36	23kW / 80m ³
HP 2400 SPLIT Premium		37	24.4kW / 80m ³
HP 2800 COMPACT Inventor	NEW	38	28.4kW / 120m ³
HP 3000 COMPACT Premium		39	30.1kW / 120m ³
HP 2800 SPLIT Inventor		40	28.4kW / 120m ³
HP 3000 SPLIT Premium		41	30.1kW / 120m ³



ACCESSORIES

measurement and regulation	Qmax-TESTER	43
	Float switches for equalizing tanks	44
	Humidity and temperature meter in 1	44
	Humidity visualization	45
	Floor grills	46
installation material and equipment	Installation material	47
	Equipment for installation and service	48
	Water connection packet	49

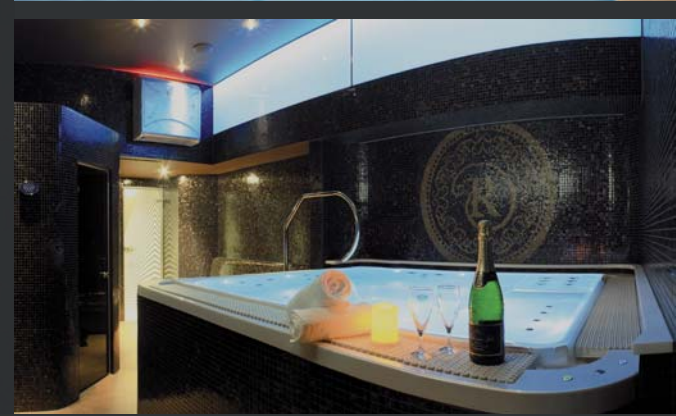
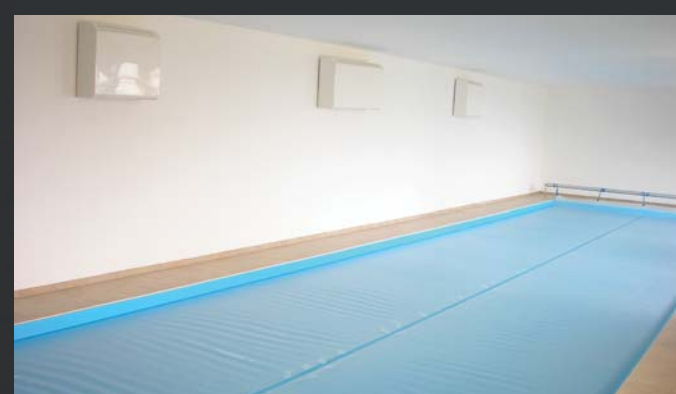

MICROWELL DRY swimming pool dehumidifiers are an innovative and visually attractive solution for indoor pools. Working on the principle of condensation, they are removing humid air from swimming pool hall, replacing it with dry and warm air. Their effective performance is proven to be the best in class. They solve humidity problems and maintain healthy environment by removing condensation and providing free heating through heat recovery.

0.05€
per liter
at average rate
0.15€ / kWh

+5°C | +42°C
application

the
WIDEST
selection
of models,
accessories and
finishes



Swimming pool dehumidifiers



36 l
30 m²

DRY 300 PLASTIK Wave

NEW DESIGN



Cover	Extraction rate (30°C, 60%RH)	Air flow
plastic (acryl)	36 l/24hrs	550 m ³ /hour



DRY 300P - 1. - 2. - 3. - 4. - 5. - 6. - 7. - 8.

Basic equipment:	Price EXW w/o VAT /EUR/
Dehumidifier, wall console, user's manual, installation layout, fixation screws	2 092
micro COMPRESSOR+ ultra QUIET+ easy INSTALL+	
1. Installation:	
S standard: on the wall	0
M mobile stand, 4 wheels, white color (RAL 9010), 230V EURO plug, 2m	218
P through-the-wall INDOOR INSTALLATION (fiberglass cover with through-the-wall ducts set and removable grilles)	176
E through-the-wall OUTDOOR INSTALLATION (40mm TTW external aluminum insulation, winter module, condensate tray defrost, -15°C)	577
2. Control:	
S standard: built-in mechanical humidistat	0
E remote wireless humidistat & thermostat DRY EASY 300 + built-in mechanical humidistat	345
W remote wired humidistat EBERLE HYG6001 + built-in mechanical humidistat	79
3. Air temperature:	
S standard: +22°C...+35°C	0
T +15°C...+35°C (with antifreeze thermostat)	57
V +22°C...+42°C (with thermostatic expansion valve)	259
A +15°C...+42°C (T+V)	279
F +5°C...+35°C (with 4-way valve hot gas defrost)	246
4. Air heating:	
S standard: without LPHW (Low Pressure Hot Water)	0
H LPHW, 3.5 kW, without regulation, contact for external thermostat 230V/5A	228
V LPHW, 3.5 kW, with solenoid valve (in standard version – external contact 230V/5A) (with EASY 300 – fully automatic regulation + no current contact)	442
E Electrical heating 2 kW	486
5. LPHW connection:	
S standard: N/A (without LPHW)	0
B from the back	0
R from right	0
L from left	0
6. micro LIGHT+	
S standard: without Pool Security microLIGHT+	0
L Pool Security microLIGHT+	147
7. Air filter:	
S standard: without air filter	0
F Air filter	52
8. Fresh air supply:	
S standard: without fresh air supply	0
F adapter, Ø 100 mm, 50 mm length, galvanized	35

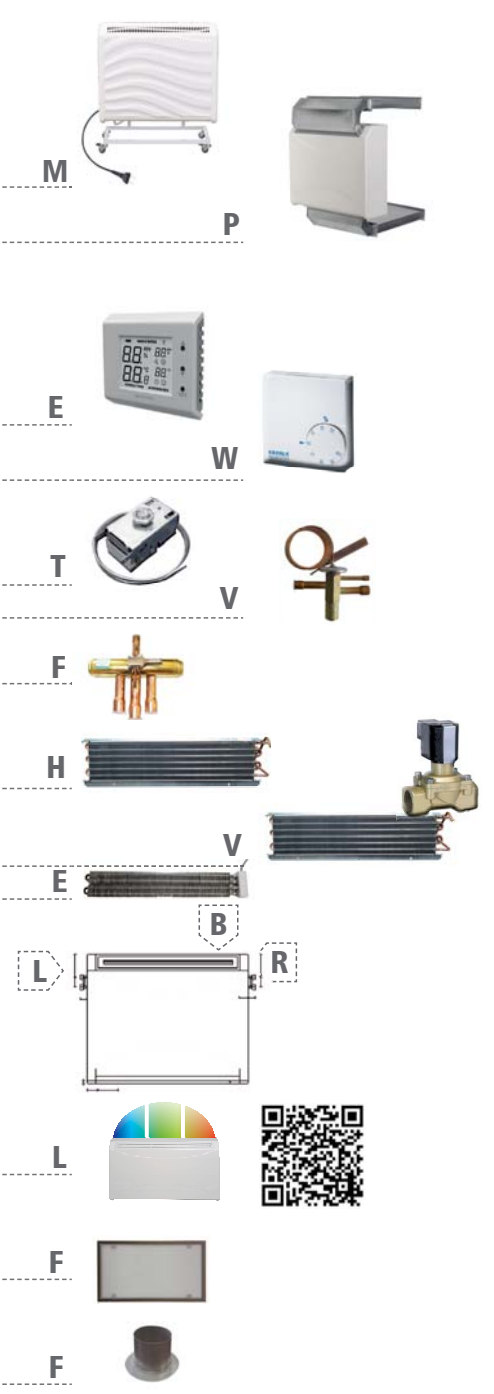

SWIMMING POOL DEHUMIDIFIERS

36 l
30 m²

DRY 300 METAL



Cover	Extraction rate (30°C, 60%RH)	Air flow
metal	36 l/24hrs	550 m ³ /hour



DRY 300M - 1. - 2. - 3. - 4. - 5. - 6. - 7. - 8. - 9.

Basic equipment:	Price EXW w/o VAT /EUR/
Dehumidifier, wall console, user's manual, installation layout, fixation screws	2 395
micro COMPRESSOR+ ultra QUIET+ easy INSTALL+	
1. Color options:	
S standard: silver color 'Tiger'	0
W white (RAL9010) glossy	0
B RAL selection, glossy finish	price on demand
M RAL selection, mat finish	price on demand
2. Installation:	
S standard: on the wall	0
M mobile stand, 4 wheels, color: silver 'Tiger', white (RAL 9010), 230V EURO plug, 2m	218
3. Control:	
S standard: built-in digital humidistat & thermostat + built-in mechanical humidistat	0
E remote wireless humidistat & thermostat DRY EASY 300 + built-in mechanical humidistat (without built-in digital humidistat & thermostat)	345
W remote wired humidistat EBERLE HYG6001 + built-in mechanical humidistat (without built-in digital humidistat & thermostat)	79
4. Air temperature:	
S standard: +22°C...+35°C	0
T +15°C...+35°C (with antifreeze thermostat)	57
V +22°C...+42°C (with thermostatic expansion valve)	259
A +15°C...+42°C (T+V)	279
F +5°C...+35°C (with 4-way valve hot gas defrost)	246
5. Air heating:	
S standard: without LPHW (Low Pressure Hot Water)	0
H LPHW, 3.5 kW, without regulation (external no current contact)	228
V LPHW, 3.5 kW, fully automatic regulation (with solenoid valve + external no current contact)	442
E Electrical heating 2 kW	486
6. LPHW connection:	
S standard: N/A (without LPHW)	0
B from the back	0
R from right	0
L from left	0
7. micro LIGHT+	
S standard: without Pool Security microLIGHT+	0
L Pool Security microLIGHT+	147
8. Air filter:	
S standard: without air filter	0
F Air filter	52
9. Fresh air supply:	
S standard: without fresh air supply	0
F adapter, Ø 100 mm, 50 mm length, galvanized	35

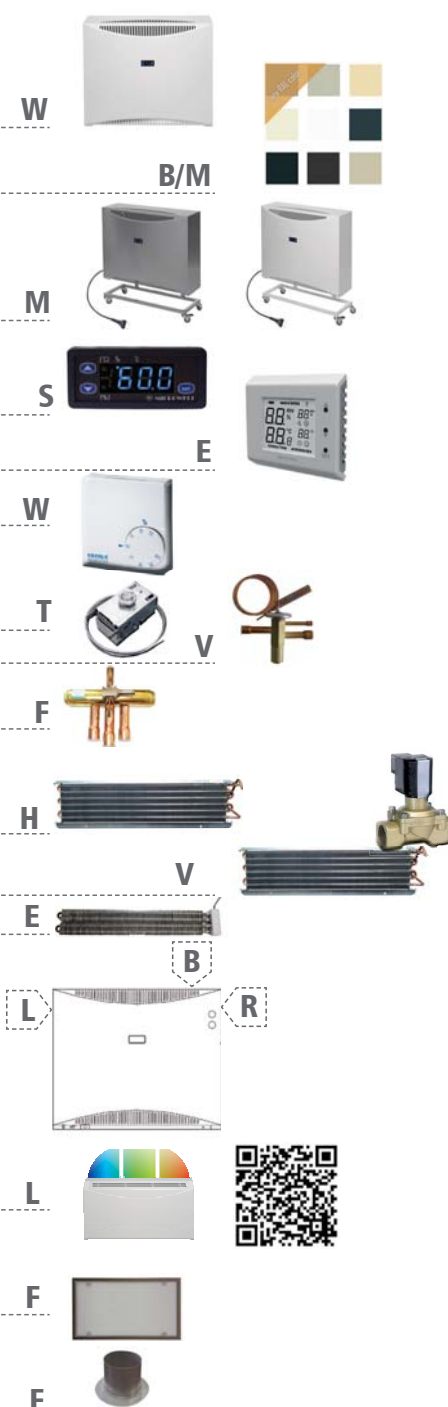



48 l
45 m²

DRY 400 PLASTIK Wave

NEW DESIGN



Cover	Extraction rate (30°C, 60%RH)	Air flow
plastic (acryl)	48 l/24hrs	600 m ³ /hour



DRY 400P - 1.-2.-3.-4.-5.-6.-7.-8.

Basic equipment:	Price EXW w/o VAT /EUR/
Dehumidifier, wall console, user's manual, installation layout, fixation screws	2 385
micro COMPRESSOR+ ultra QUIET+ easy INSTALL+	
1. Installation:	
S standard: on the wall	0
M mobile stand, 4 wheels, white color (RAL 9010), 230V EURO plug, 2m	218
P through-the-wall INDOOR INSTALLATION (fiberglass cover with through-the-wall ducts set and removable grilles)	176
E through-the-wall OUTDOOR INSTALLATION (40mm TTW external aluminum insulation, winter module, condensate tray defrost, -15°C)	577
2. Control:	
S standard: built-in mechanical humidistat	0
E remote wireless humidistat & thermostat DRY EASY 300 + built-in mechanical humidistat	345
W remote wired humidistat EBERLE HYG6001 + built-in mechanical humidistat	79
3. Air temperature:	
S standard: +22°C...+42°C	0
T +15°C...+42°C (with antifreeze thermostat)	57
4. Air heating:	
S standard: without LPHW (Low Pressure Hot Water)	0
H LPHW, 3.5 kW, without regulation, contact for external thermostat 230V/5A	228
V LPHW, 3.5 kW, with solenoid valve (in standard version – external contact 230V/5A) (with EASY 300 – fully automatic regulation + no current contact)	442
E Electrical heating 2 kW	486
5. LPHW connection:	
S standard: N/A (without LPHW)	0
B from the back	0
R from right	0
L from left	0
6. micro LIGHT+	
S standard: without Pool Security microLIGHT+	0
L Pool Security microLIGHT+	147
7. Air filter:	
S standard: without air filter	0
F Air filter	52
8. Fresh air supply:	
S standard: without fresh air supply	0
F adapter, Ø 100 mm, 50 mm length, galvanized	35

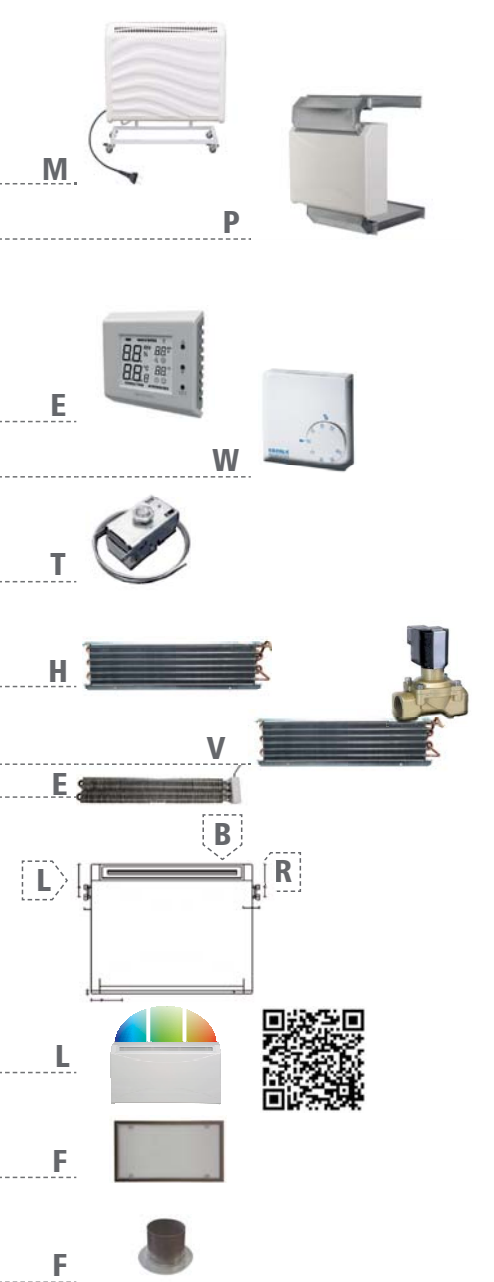

SWIMMING POOL DEHUMIDIFIERS

48 l
45 m²

DRY 400 METAL



Cover	Extraction rate (30°C, 60%RH)	Air flow
metal	48 l/24hrs	600 m ³ /hour

DRY 400M - 1. - 2. - 3. - 4. - 5. - 6. - 7. - 8. - 9.

Basic equipment:	Price EXW w/o VAT /EUR/
Dehumidifier, wall console, user's manual, installation layout, fixation screws	2 865
micro COMPRESSOR+ ultra QUIET+ easy INSTALL+	
1. Color options:	
S standard: silver color 'Tiger'	0
W white (RAL9010) glossy	0
B RAL selection, glossy finish	price on demand
M RAL selection, mat finish	price on demand
2. Installation:	
S standard: on the wall	0
M mobile stand, 4 wheels, color: silver 'Tiger', white (RAL 9010), 230V EURO plug, 2m	218
3. Control:	
S standard: built-in digital humidistat & thermostat + built-in mechanical humidistat	0
E remote wireless humidistat & thermostat DRY EASY 300 + built-in mechanical humidistat (without built-in digital humidistat & thermostat)	345
W remote wired humidistat EBERLE HYG6001 + built-in mechanical humidistat (without built-in digital humidistat & thermostat)	79
4. Air temperature:	
S standard: +22°C...+42°C	0
T +15°C...+42°C (with antifreeze thermostat)	57
5. Air heating:	
S standard: without LPHW (Low Pressure Hot Water)	0
H LPHW, 3.5 kW, without regulation (external no current contact)	228
V LPHW, 3.5 kW, fully automatic regulation (with solenoid valve + external no current contact)	442
E Electrical heating 2 kW	486
6. LPHW connection:	
S standard: N/A (without LPHW)	0
B from the back	0
R from right	0
L from left	0
7. micro LIGHT+	
S standard: without Pool Security microLIGHT+	0
L Pool Security microLIGHT+	147
8. Air filter:	
S standard: without air filter	0
F Air filter	52
9. Fresh air supply:	
S standard: without fresh air supply	0
F adapter, Ø 100 mm, 50 mm length, galvanized	35

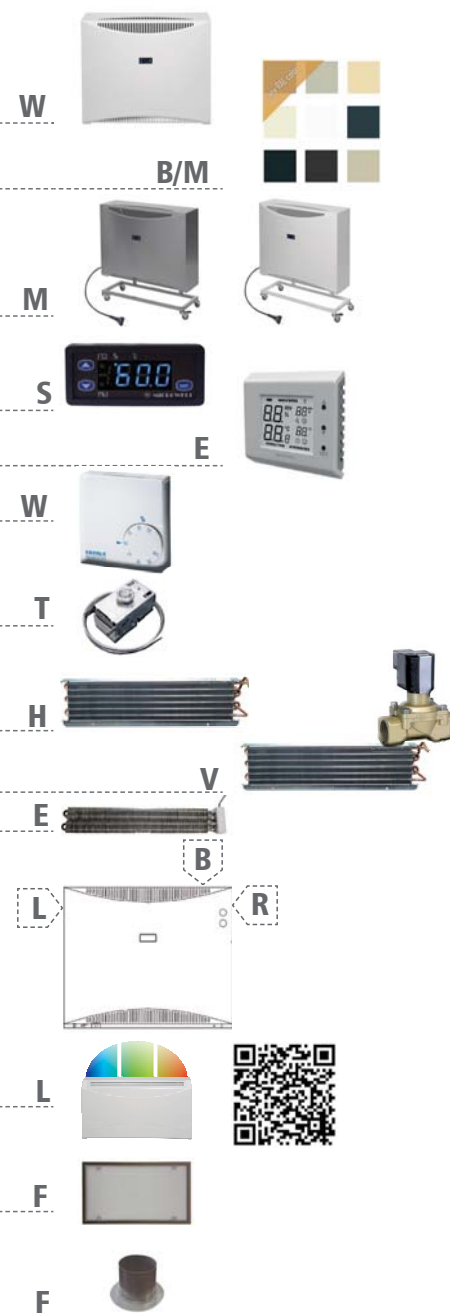



66 l
60 m²

DRY 500 PLASTIK Wave

NEW DESIGN
from June 2018



Cover	Extraction rate (30°C, 60%RH)	Air flow
plastic (acryl)	66 l/24hrs	800 m ³ /hour

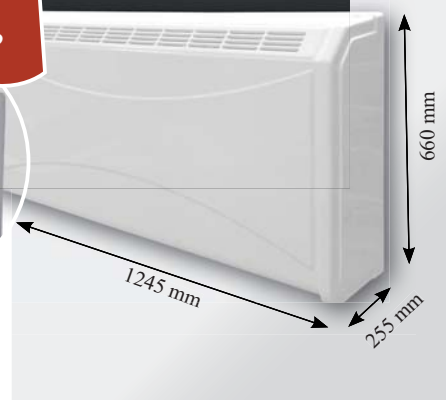

DRY 500P - 1. - 2. - 3. - 4. - 5. - 6. - 7. - 8.

Basic equipment:

Dehumidifier, wall console, user's manual, installation layout, fixation screws

Price EXW
w/o VAT /EUR/

3 080

micro COMPRESSOR+ ultra QUIET+ easy INSTALL+

1. Installation:

S standard: on the wall	0
M mobile stand, 4 wheels, white color (RAL 9010), 230V EURO plug, 2m	245
P through-the-wall INDOOR INSTALLATION (fiberglass cover with through-the-wall ducts set and removable grilles)	233
E through-the-wall OUTDOOR INSTALLATION (40mm TTW external aluminum insulation, winter module, condensate tray defrost, -15°C)	577

2. Control:

S standard: built-in mechanical humidistat	0
E remote wireless humidistat & thermostat DRY EASY 300 + built-in mechanical humidistat	345
W remote wired humidistat EBERLE HYG6001 + built-in mechanical humidistat	79

3. Air temperature:

S standard: +22°C...+35°C	0
T +15°C...+35°C (with antifreeze thermostat)	57
V +22°C...+42°C (with thermostatic expansion valve)	259
A +15°C...+42°C (T+V)	279
F +5°C...+35°C (with 4-way valve hot gas defrost)	246

4. Air heating:

S standard: without LPHW (Low Pressure Hot Water)	0
H LPHW, 5 kW, without regulation, contact for external thermostat 230V/5A	246
V LPHW, 5 kW, with solenoid valve (in standard version – external contact 230V/5A) (with EASY 300 – fully automatic regulation + no current contact)	458
E Electrical heating 2 kW	507

5. LPHW connection:

S standard: N/A (without LPHW)	0
B from the back	0
R from right	0
L from left	0

6. micro LIGHT+

S standard: without Pool Security microLIGHT+	0
L Pool Security microLIGHT+	147

7. Air filter:

S standard: without air filter	0
F Air filter	54

8. Fresh air supply:

S standard: without fresh air supply	0
F adapter, Ø 100 mm, 50 mm length, galvanized	35

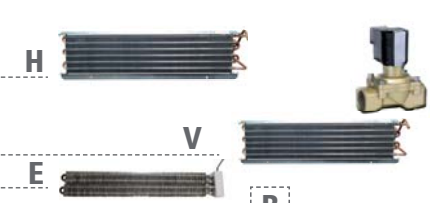

SWIMMING POOL DEHUMIDIFIERS

66 l
60 m²

DRY 500 METAL



Cover	Extraction rate (30°C, 60%RH)	Air flow
metal	66 l/24hrs	800 m ³ /hour



DRY 500M - 1. - 2. - 3. - 4. - 5. - 6. - 7. - 8. - 9.

Basic equipment:

Dehumidifier, wall console, user's manual, installation layout, fixation screws

Price EXW
w/o VAT /EUR/

3 495

micro COMPRESSOR+ ultra QUIET+ easy INSTALL+

1. Color options:

S standard: silver color 'Tiger'	0
W white (RAL9010) glossy	0
B RAL selection, glossy finish	price on demand
M RAL selection, mat finish	price on demand

2. Installation:

S standard: on the wall	0
M mobile stand, 4 wheels, color: silver 'Tiger', white (RAL 9010), 230V EURO plug, 2m	245

3. Control:

S standard: built-in digital humidistat & thermostat + built-in mechanical humidistat	0
E remote wireless humidistat & thermostat DRY EASY 300 + built-in mechanical humidistat (without built-in digital humidistat & thermostat)	345
W remote wired humidistat EBERLE HYG6001 + built-in mechanical humidistat (without built-in digital humidistat & thermostat)	79

4. Air temperature:

S standard: +22°C...+35°C	0
T +15°C...+35°C (with antifreeze thermostat)	57
V +22°C...+42°C (with thermostatic expansion valve)	259
A +15°C...+42°C (T+V)	279
F +5°C...+35°C (with 4-way valve hot gas defrost)	246

5. Air heating:

S standard: without LPHW (Low Pressure Hot Water)	0
H LPHW, 3.5 kW, without regulation (external no current contact)	246
V LPHW, 3.5 kW, fully automatic regulation (with solenoid valve + external no current contact)	458
E Electrical heating 2 kW	507

6. LPHW connection:

S standard: N/A (without LPHW)	0
B from the back	0
R from right	0
L from left	0

7. micro LIGHT+

S standard: without Pool Security microLIGHT+	0
L Pool Security microLIGHT+	147

8. Air filter:

S standard: without air filter	0
F Air filter	54

9. Fresh air supply:

S standard: without fresh air supply	0
F adapter, Ø 100 mm, 50 mm length, galvanized	35

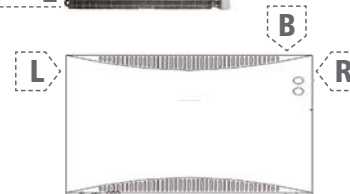
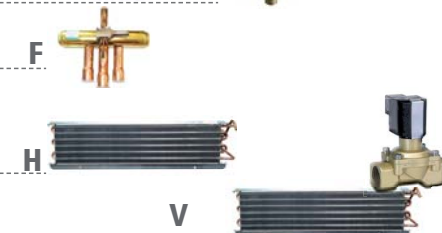



36 l
30 m²

DRY 300 SILVER

48 l
45 m²

DRY 400 SILVER

66 l
60 m²

DRY 500 SILVER

Cover	Extraction rate (30°C, 60%RH)	Air flow	Extraction rate (30°C, 60%RH)	Air flow	Extraction rate (30°C, 60%RH)	Air flow
stainless steel	36 l/24hrs	550 m ³ /hour	48 l/24hrs	600 m ³ /hour	66 l/24hrs	800 m ³ /hour



Basic equipment:

Dehumidifier, wall console, user's manual, installation layout, fixation screws

micro COMPRESSOR+ ultra QUIET+ easy INSTALL+

Price EXW
w/o VAT /EUR/

DRY 300S - 2. - 3. - 4. - 5. - 6. - 7. - 8. - 9.

with stainless steel cover

2 645



Other accessory selection:
see page No. 6
DRY 300 METAL

DRY 400S - 2. - 3. - 4. - 5. - 6. - 7. - 8. - 9.

with stainless steel cover

3 145



Other accessory selection:
see page No. 8
DRY 400 METAL

DRY 500S - 2. - 3. - 4. - 5. - 6. - 7. - 8. - 9.

with stainless steel cover

3 895



Other accessory selection:
see page No. 10
DRY 500 METAL

DRY 300S



DRY 400S



DRY 500S



SWIMMING POOL DEHUMIDIFIERS

90L
90 m²

DRY 800 METAL

120 l
120 m²

DRY 1200 METAL



Cover	Extraction rate (30°C, 60%RH)	Air flow
metal	90 l/24hrs	1100 m ³ /hour



Extraction rate (30°C, 60%RH)	Air flow
120 l/24hrs	1200 m ³ /hour

DRY 800M/1200M - 1. - 2. - 3. - 4. - 5. - 6. - 7. - 8. - 9.

Basic equipment:	Model:	Price EXW w/o VAT /EUR/
Dehumidifier, floor feet, user's manual	DRY 800 METAL	4 345
micro COMPRESSOR+ ultra QUIET+	DRY 1200 METAL	4 990
easy INSTALL+		
1. Color options:		
S standard: silver color „Tiger“		0
W white (RAL9010) glossy		0
B RAL selection, glossy finish		price on demand
M RAL selection, mat finish		price on demand
2. Installation:		
S standard: on the floor		0
M on the wall (floor feet + wall console)		135
P through-the-wall INDOOR INSTALLATION (cover with AIR IN from the back, AIR OUT to the back/to the top, including the through-the-wall ducts set and removable grilles, color: white)		278
E through-the-wall OUTDOOR INSTALLATION (40mm TTW external aluminum insulation, winter module, condensate tray defrost, -15°C)		577
3. Control:		
S standard: built-in digital humidistat & thermostat + built-in mechanical humidistat		0
E remote wireless humidistat & thermostat DRY EASY 300 + built-in mechanical humidistat (without built-in digital humidistat & thermostat)		345
W remote wired humidistat EBERLE HYG6001 + built-in mechanical humidistat (without built-in digital humidistat & thermostat)		79
4. Air temperature:		
S standard: +22°C...+35°C		0
T +15°C...+35°C (with antifreeze thermostat)		57
5. Air heating:		
S standard: without LPHW (Low Pressure Hot Water)		0
H LPHW, 7 kW, without regulation (external no current contact)		313
V LPHW, 7 kW, fully automatic regulation (with solenoid valve + external no current contact)		524
E Electrical heating 3 kW		564
6. LPHW connection:		
S standard: N/A (without LPHW)		0
B from the back		0
R from right		0
7. micro LIGHT+		
S standard: without Pool Security microLIGHT+		0
L Pool Security microLIGHT+		147
8. Air filter:		
S standard: without air filter		0
F Air filter		54
9. Fresh air supply:		
S standard: without fresh air supply		0
F adapter, Ø 100 mm, 50 mm length, galvanized		35

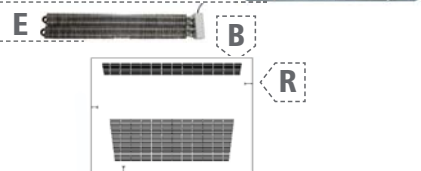
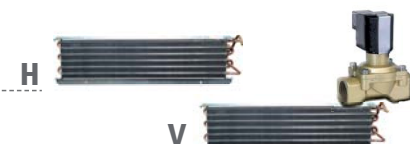
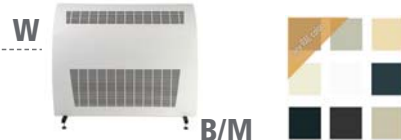
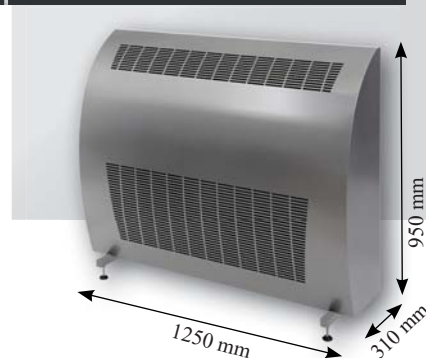



32 l
30 m²

DRY 300 DUCT

NEW



Cover	Extraction rate (30°C, 60%RH)	Air flow
metal	32 l/24hrs	500 m ³ /hour, 200 Pa

DRY 300D - 1. - 2. - 3. - 4. - 5.

Basic equipment:

Price EXW
w/o VAT /EUR/

Dehumidifier, wall console, fixation screws, user's manual, installation layout

AIR IN from the bottom, **AIR OUT** to the top

2460

micro COMPRESSOR+ micro CONTROL+

1. Control:

S standard: built-in digital humidistat & thermostat
+ built-in mechanical humidistat

0

E remote wireless humidistat & thermostat DRY EASY 300
+ built-in mechanical humidistat (without built-in digital humidistat & thermostat)

345

W remote wired humidistat EBERLE HYG6001
+ built-in mechanical humidistat (without built-in digital humidistat & thermostat)

79

2. Air temperature:

S standard: +22°C...+35°C

0

T +15°C...+35°C (with antifreeze thermostat)

57

V +22°C...+42°C (with thermostatic expansion valve)

259

A +15°C...+42°C (T+V)

279

F +5°C...+35°C (with 4-way valve hot gas defrost)

246

3. Air heating:

S standard: without LPHW (Low Pressure Hot Water)

0

H LPHW, 3.5 kW, without regulation (external no current contact)

246

V LPHW, 3.5 kW, fully automatic regulation
(with solenoid valve + external no current contact)

458

E Electrical heating, 2 kW

486

4. LPHW connection:

S standard: N/A (without LPHW)

0

B from the back

0

R from right

0

5. Air filter:

S standard: without air filter

0

F Air filter

56



Various range of ACCESSORIES:

Air ducting and grills

Floor grills

more on page 46

micro LIGHT+ + INFINITY more on page 45



DUCTED SWIMMING POOL DEHUMIDIFIERS

43 l
40 m²

DRY 400 DUCT

Cover	Extraction rate (30°C, 60%RH)	Air flow
metal	43 l/24hrs	500 m ³ /hour, 200 Pa

NEW



DRY 400D - 1. - 2. - 3. - 4. - 5.

Basic equipment:

Dehumidifier, wall console, fixation screws, user's manual, installation layout

AIR IN from the bottom, **AIR OUT** to the top

Price EXW
w/o VAT /EUR/

2850

micro COMPRESSOR+ micro CONTROL+

1. Control:

S standard: built-in digital humidistat & thermostat
+ built-in mechanical humidistat

0

E remote wireless humidistat & thermostat DRY EASY 300
+ built-in mechanical humidistat (without built-in digital humidistat & thermostat)

345

W remote wired humidistat EBERLE HYG6001
+ built-in mechanical humidistat (without built-in digital humidistat & thermostat)

79

2. Air temperature:

S standard: +22°C...+42°C

0

T +15°C...+42°C (with antifreeze thermostat)

57

3. Air heating:

S standard: without LPHW (Low Pressure Hot Water)

0

H LPHW, 3.5 kW, without regulation (external no current contact)

246

V LPHW, 3.5 kW, fully automatic regulation
(with solenoid valve + external no current contact)

458

E Electrical heating, 2 kW

486

4. LPHW connection:

S standard: N/A (without LPHW)

0

B from the back

0

R from right

0

5. Air filter:

S standard: without air filter

0

F Air filter

56

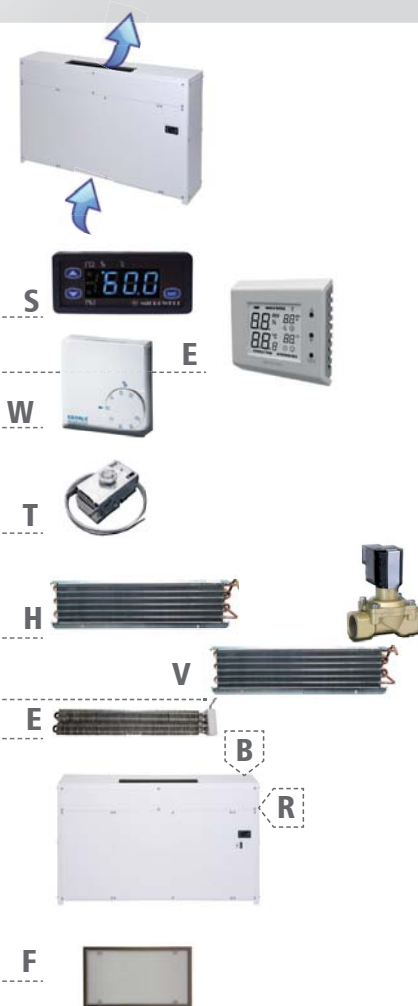

Various range of ACCESSORIES:

Air ducting and grills

Floor grills

more on page 46

micro LIGHT+ + INFINITY more on page 45





52 l
50 m²

DRY 500 DUCT



Cover	Extraction rate (30°C, 60%RH)	Air flow
metal	52 l/24hrs	1000 m ³ /hour, 200 Pa



DRY 500D - 1. - 2. - 3. - 4. - 5.

Basic equipment:

Price EXW
w/o VAT /EUR/

Dehumidifier, wall console, fixation screws, user's manual, installation layout

AIR IN from the bottom, **AIR OUT** to the top

3 570

micro COMPRESSOR +

micro CONTROL +

1. Control:

S standard: built-in digital humidistat & thermostat
+ built-in mechanical humidistat

0

E remote wireless humidistat & thermostat DRY EASY 300
+ built-in mechanical humidistat (without built-in digital humidistat & thermostat)

345

W remote wired humidistat EBERLE HYG6001
+ built-in mechanical humidistat (without built-in digital humidistat & thermostat)

79

2. Air temperature:

S standard: +22°C...+35°C

0

T +15°C...+35°C (with antifreeze thermostat)

57

V +22°C...+42°C (with thermostatic expansion valve)

259

A +15°C...+42°C (T+V)

279

F +5°C...+35°C (with 4-way valve hot gas defrost)

246

3. Air heating:

S standard: without LPHW (Low Pressure Hot Water)

0

H LPHW, 5 kW, without regulation (external no current contact)

246

V LPHW, 5 kW, fully automatic regulation

(with solenoid valve + external no current contact)

458

E Electrical heating, 2 kW

486

4. LPHW connection:

S standard: N/A (without LPHW)

0

B from the back

0

R from right

0

5. Air filter:

S standard: without air filter

0

F Air filter

56



Various range of ACCESSORIES:

Air ducting and grills

Floor grills

more on page 46

micro LIGHT + INFINITY more on page 45



DUCTED SWIMMING POOL DEHUMIDIFIERS

88 l
80 m²

DRY 800 DUCT

Cover	Extraction rate (30°C, 60%RH)	Air flow
metal	88 l/24hrs	1100 m ³ /hour, 170 Pa

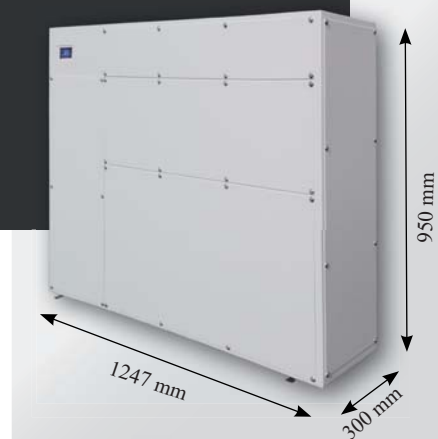

DRY 800D - 1. - 2. - 3. - 4. - 5.

Basic equipment:

Dehumidifier, wall console, fixation screws, user's manual, installation layout

AIR IN from the back, **AIR OUT** to the top/back

Price EXW
w/o VAT /EUR/

4 590

micro COMPRESSOR+ micro CONTROL+

1. Control:

S standard: built-in digital humidistat & thermostat + built-in mechanical humidistat	0
E remote wireless humidistat & thermostat DRY EASY 300 + built-in mechanical humidistat (without built-in digital humidistat & thermostat)	345
W remote wired humidistat EBERLE HYG6001 + built-in mechanical humidistat (without built-in digital humidistat & thermostat)	79

2. Air temperature:

S standard: +22°C...+35°C	0
T +15°C...+35°C (with antifreeze thermostat)	57

3. Air heating:

S standard: without LPHW (Low Pressure Hot Water)	0
H LPHW, 7 kW, without regulation (external no current contact)	313
V LPHW, 7 kW, fully automatic regulation (with solenoid valve + external no current contact)	524
E Electrical heating, 3 kW	564

4. LPHW connection:

S standard: N/A (without LPHW)	0
B from the back	0
R from right	0

5. Air filter:

S standard: without air filter	0
F Air filter	56



Various range of ACCESSORIES:

Air ducting and grills

Floor grills

more on page 46

micro LIGHT+ + INFINITY

more on page 45





112 l
110 m²

DRY 1200 DUCT



Cover	Extraction rate (30°C, 60%RH)	Air flow
metal	112 l/24hrs	1200 m ³ /hour, 145 Pa

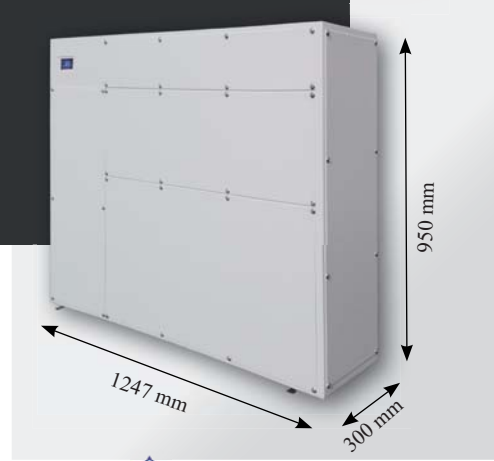

DRY 1200D - 1. - 2. - 3. - 4. - 5.

Basic equipment:

Dehumidifier, wall console, fixation screws, user's manual, installation layout

AIR IN from the back, **AIR OUT** to the top/back

Price EXW
w/o VAT /EUR/

5 490

micro COMPRESSOR+ micro CONTROL+

1. Control:

S standard: built-in digital humidistat & thermostat + built-in mechanical humidistat	0
E remote wireless humidistat & thermostat DRY EASY 300 + built-in mechanical humidistat (without built-in digital humidistat & thermostat)	345
W remote wired humidistat EBERLE HYG6001 + built-in mechanical humidistat (without built-in digital humidistat & thermostat)	79

2. Air temperature:

S standard: +22°C...+35°C	0
T +15°C...+35°C (with antifreeze thermostat)	57

3. Air heating:

S standard: without LPHW (Low Pressure Hot Water)	0
H LPHW, 7 kW, without regulation (external no current contact)	313
V LPHW, 7 kW, fully automatic regulation (with solenoid valve + external no current contact)	524
E Electrical heating, 3 kW	564

4. LPHW connection:

S standard: N/A (without LPHW)	0
B from the back	0
R from right	0

5. Air filter:

S standard: without air filter	0
F Air filter	56



Various range of ACCESSORIES:

Air ducting and grills

Floor grills

more on page 46

micro LIGHT+ + INFINITY more on page 45



CEILING SWIMMING POOL DEHUMIDIFIERS

67 l
60 m²

DRY SIREN mono



Cover	Extraction rate (30°C, 60%RH)	Air flow
plastic (acryl)	67 l/24hrs	1000 m ³ /hour



DRY Siren



CEILING UNIT



COMPRESSOR UNIT

DRY SIREN mono - 1. - 2.

Basic equipment:

ceiling unit, compressor unit, wall consoles for compressor unit, ceiling lifting mechanism, tablet, Bluetooth speaker, LED light, hot gas defrost, user's manual

Price EXW
w/o VAT /EUR/

5 390

- micro LIGHT+
- micro ENERGY+
- micro SAFETY+
- micro COMPRESSOR+
- ultra QUIET+

1. Ceiling unit installation:

S concrete ceiling	0
B wooden beam	0

2. Cable length:

S 10m	0
M 20m	46
L 30m	67



control
by SMART
devices



micro SAFETY+

microSAFETY+ is a supervision system included by standard in DRY SIREN swimming pool dehumidifier models. The system monitors each DRY SIREN on constant basis. In the case of a sign of technical problem or possible malfunction, the system creates a comprehensive report with technical data and sends it to Microwell automatically. Microwell has then the ability to advise the distributor, reseller or installer upper hand to take necessary measures to rectify the problem and avoid further damages. microSAFETY+ effectively protects your property 24/7. The data transfer is securely ciphered.





134 l
120 m²

DRY SIREN due



Cover	Extraction rate (30°C, 60%RH)	Air flow
plastic (acryl)	134 l/24hrs	2000 m ³ /hour

DRY SIREN due - 1. - 2.

Basic equipment:

2x ceiling unit, compressor unit, wall consoles for compressor unit, ceiling lifting mechanism, tablet, Bluetooth speaker, LED light, hot gas defrost, user's manual

Price EXW
w/o VAT /EUR/

- micro LIGHT+
- micro ENERGY+
- micro SAFETY+
- micro COMPRESSOR+
- ultra QUIET+

9 780

1. Ceiling unit installation:

S concrete ceiling	0
B wooden beam	0

2. Cable length:

S 10m	0
M 20m	46
L 30m	67



2 x 278 mm

2 x Ø 1205 mm

2 x CEILING UNIT



COMPRESSOR UNIT



control by SMART devices



FULL CONTROL

DRY SIREN



mobile application allows you to actively take control of dehumidification process, LED lamp, Bluetooth speaker, microLIGHT+ and unit's self-diagnosis. From anywhere in the world, anytime, you are able to observe your unit's current status and air relative humidity and air temperature.



DEHUMIDIFIERS FOR GALLERIES

36 l
30 m²

DRY 300 GALLERY



Cover	Extraction rate (30°C, 60%RH)	Air flow
wooden wardrobe construction	36 l/24hrs	550 m ³ /hour



DRY 300G - 1. - 2. - 3. - 4.

Basic equipment:

Fully mobile dehumidifier, 20 liter condensation tank, user's manual

Price EXW
w/o VAT /EUR/

2 620

micro COMPRESSOR+

1. Color options:

S standard: white glossy color (RAL9010)	0
B Beech	0
C Cherry	0
O Oak	0
W Nut	0

2. Control:

S standard: built-in digital humidistat & thermostat	0
E remote wireless humidistat & thermostat DRY EASY 300 + built-in mechanical humidistat (without built-in digital humidistat & thermostat)	345

3. Air temperature:

S standard: +15°C...+35°C	0
F +5°C...+35°C (with 4-way valve hot gas defrost)	246

4. Air filter:

S standard: without air filter	0
F Air filter	56

B - C



O - W

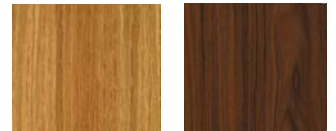

E



F



F



INDUSTRIAL DEHUMIDIFIERS

	40 l day T40		90 l day T90		120 l day T120	
Cover	Operating range	Nominal air delivery	Operating range	Nominal air delivery	Operating range	Nominal air delivery
metal	0°C - 35°C	500 m³/hour	0°C - 35°C	1100 m³/hour	0°C - 35°C	1500 m³/hour

Basic equipment:

Price EXW
w/o VAT /EUR/

Fully mobile dehumidifier, user's manual

Designed for drying up buildings, new construction sites, warehouses, as well as non-heated and flooded buildings with high level of humidity.

easy **INSTALL+**

T40

770

T40 High Temperature

Operational temperature range: 0°C ... +50°C

912

T90

1 056

T120

1 223



T90



T120



ENERGY CONSUMPTION
from **650w**



Final prices. Rebate does not apply on these items.

v. 01/2018

/ 21

INDUSTRIAL DEHUMIDIFIERS

	40 l day TE40		90 l day TE90		120 l day TE120	
Cover	Operating range	Nominal air delivery	Operating range	Nominal air delivery	Operating range	Nominal air delivery
metal	0°C - 35°C	500 m³/hour	0°C - 35°C	1100 m³/hour	0°C - 35°C	1500 m³/hour

Additional **electrical heater-2kW** helps speed up the drying process.

Basic equipment:

Price EXW
w/o VAT /EUR/

Fully mobile dehumidifier, user's manual

Designed for drying up buildings, new construction sites, warehouses, as well as non-heated and flooded buildings with high level of humidity.

easy **INSTALL+**

TE40 with Electrical heater, 2 kW

831



TE90 with Electrical heater, 2 kW

1 117



TE120 with Electrical heater, 2 kW

1 284

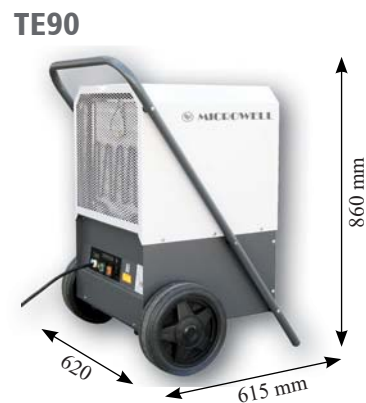

ENERGY CONSUMPTION
from **650w**

COMPLETE CAPACITY RANGE

HP COMPACT and HP SPLIT heat pumps come in three capacities (HP 1000, HP 2000, HP 3000) and three models (OMEGA, PREMIUM, INVENTOR). They are suitable for every swimming pool and various applications.

COP
up to **21.06**

at Air 26°C / Water 26°C / Humidity 80%

FULL YEAR
heating
-15°C|+40°C

**Automatic
HEATING
COOLING**

included

WIFI
control

possible



Swimming pool heat pumps

SWIMMING POOL HEAT PUMPS

10.7 kW
40 m³

HP 1000 COMPACT Omega



Cover	COP	Heating output	Cooling output
metal	5.2 - 7.0 (A26 W26)*	9.7 - 13.1 kW (A26 W26)*	7.6 kW (A30 W35)*



HP 1000 COMPACT O - 1. - 2. - 3. - 4. - 5.

Basic equipment:	Price EXW w/o VAT /EUR/
Heat pump, user's manual	
micro COMPRESSOR + micro ECONOMY + ultra QUIET +	1 590
anti VIBRATION + anti FREEZE +	
1. Condensate tray defrost:	
S standard: without defrost	0
W with defrost	296
2. Full year modification:	
S standard: without WINTER module (-5°C...+40°C)	0
W with WINTER module (-15°C...+40°C)	325
3. Heat exchanger frost protection:	
S standard: without frost protection	0
W with frost protection	296
4. Control display placement:	
S standard: control display placed on the heat pump	0
W wall installation (out of the heat pump), includes wall plaster box, 30m cable	37
5. WIFI:	
S standard: without WIFI	0
W with WIFI	100
Protection cover:	
<i>Rebate does not apply on this item. This is the actual purchase price.</i>	72
Complete WINTER PACKAGE for better price:	
The package includes: 1. Condensate tray defrost, 2. WINTER module, 3. Heat exchanger frost protection	815



S

W



W

Available as of 1st June



NEW

Full range of ACCESSORIES /more on pages 47, 49/



(*) A - air temperature
W - water temperature
RH - measured at 35% - 63% - 80% relative humidity



11.3 kW
40 m³

HP 1100 COMPACT Premium



Cover	COP	Heating output	Cooling output
metal	5.9 - 7.9 (A26 W26)*	10.3 - 13.9 kW (A26 W26)*	8.2 kW (A30 W35)*



HP 1100 COMPACT P - 1. - 2. - 3. - 4. - 5.

Basic equipment:	Price EXW w/o VAT /EUR/
Heat pump, user's manual	
micro COMPRESSOR + micro ECONOMY + ultra QUIET +	2 230
anti VIBRATION + anti FREEZE +	
1. Condensate tray defrost:	
S standard: without defrost	0
W with defrost	296
2. Full year modification:	
S standard: without WINTER module (-5°C...+40°C)	0
W with WINTER module (-15°C...+40°C)	325
3. Heat exchanger frost protection:	
S standard: without frost protection	0
W with frost protection	296
4. Control display placement:	
S standard: control display placed on the heat pump	0
W wall installation (out of the heat pump), includes wall plaster box, 30m cable	37
5. WIFI:	
S standard: without WIFI	0
W with WIFI	100
Protection cover:	
<i>Rebate does not apply on this item. This is the actual purchase price.</i>	72
Complete WINTER PACKAGE for better price:	
The package includes: 1. Condensate tray defrost, 2. WINTER module, 3. Heat exchanger frost protection	815



Available as of 1st June

NEW

Full range of ACCESSORIES /more on pages 47, 49/



TESTED APPROVED



EXCHANGER EQUIPPED WITH **0.6 m² of TITANIUM**

SWIMMING POOL HEAT PUMPS

10.7 kW
40 m³

HP 1000 SPLIT Omega



Cover	COP	Heating output	Cooling output
metal	5.2 - 7.0 (A26 W26)*	9.7 - 13.1 kW (A26 W26)*	7.6 kW (A30 W35)*

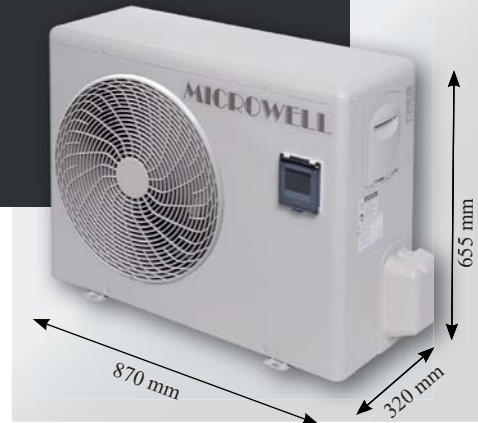

HP 1000 SPLIT O - 1. - 2. - 3. - 4. - 5. - 6. - 7.

Basic equipment:	Price EXW w/o VAT /EUR/
Air unit, user's manual	
micro COMPRESSOR + anti VIBRATION + micro ECONOMY + anti FREEZE + ultra QUIET +	930
1. Hydro kit (unit with water heat exchanger):	
S standard: without box (installation in technical room)	660
W with box (installation in soil)	790
2. Control display placement:	
S standard: digital display placed on outside unit (air unit)	0
H digital display on remote heat exchanger (heat exchanger box to be installed in interior)	0
W wall installation (out of the heat pump), includes wall plaster box, 30m cable	21
3. WIFI:	
S standard: without WIFI	0
W with WIFI	100
4. Connecting cable length:	
S standard: 10 m	0
M 20 m	46
5. Condensate tray defrost:	
S standard: without defrost	0
W with defrost	296
6. Heat exchanger frost protection:	
S standard: without frost protection	0
W with frost protection	296
7. Full year modification:	
S standard: without WINTER module (-5°C...+40°C)	0
W with WINTER module (-15°C...+40°C)	325
Protection cover:	
<i>Rebate does not apply on this item. This is the actual purchase price.</i>	60
Complete WINTER PACKAGE for better price:	
The package includes: 1. Condensate tray defrost, 2. WINTER module, 3. Heat exchanger frost protection	815

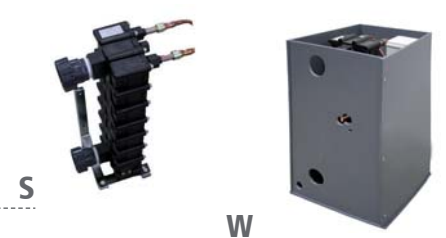

Available as of 1st June

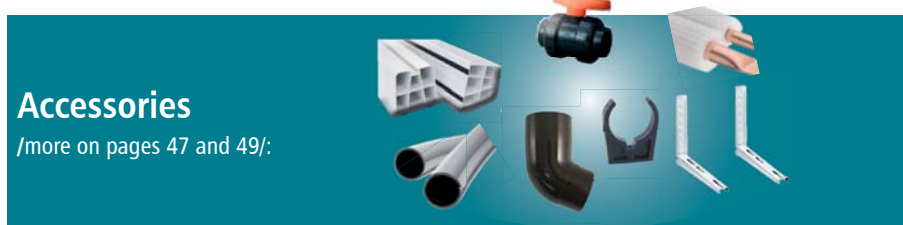

Accessories

/more on pages 47 and 49/



(*) A - air temperature
W - water temperature
RH - measured at 35% - 63% - 80% relative humidity



11.3 kW
40 m³

HP 1100 SPLIT Premium



Cover	COP	Heating output	Cooling output
metal	5.9 - 7.9 (A26 W26)*	10.3 - 13.9 kW (A26 W26)*	8.2 kW (A30 W35)*



HP 1100 SPLIT P - 1. - 2. - 3. - 4. - 5. - 6. - 7.

Basic equipment:	Price EXW w/o VAT /EUR/
Air unit, user's manual micro COMPRESSOR + micro ECONOMY + ultra QUIET + anti VIBRATION + anti FREEZE +	1 310
1. Hydro kit (unit with water heat exchanger):	
S standard: without box (installation in technical room)	805
W with box (installation in soil)	930
2. Control display placement:	
S standard: digital display placed on outside unit (air unit)	0
H digital display on remote heat exchanger (heat exchanger box to be installed in interior)	0
W wall installation (out of the heat pump), includes wall plaster box, 30m cable	21
3. WIFI:	
S standard: without WIFI	0
W with WIFI	100
4. Connecting cable length:	
S standard: 10 m	0
M 20 m	46
5. Condensate tray defrost:	
S standard: without defrost	0
W with defrost	296
6. Heat exchanger frost protection:	
S standard: without frost protection	0
W with frost protection	296
7. Full year modification:	
S standard: without WINTER module (-5°C...+40°C)	0
W with WINTER module (-15°C...+40°C)	325
Protection cover:	
<i>Rebate does not apply on this item. This is the actual purchase price.</i>	60
Complete WINTER PACKAGE for better price:	
The package includes: 1. Condensate tray defrost, 2. WINTER module, 3. Heat exchanger frost protection	815



S

W

S

H

W



W



Available as of 1st June



Accessories
/more on pages 47 and 49/



SWIMMING POOL HEAT PUMPS

14.1 kW
60 m³

HP 1400 COMPACT Omega



Cover	COP	Heating output	Cooling output
metal	5.2 - 7.0 (A26 W26)*	12.8 - 17.2 kW (A26 W26)*	11.0 kW (A30 W35)*

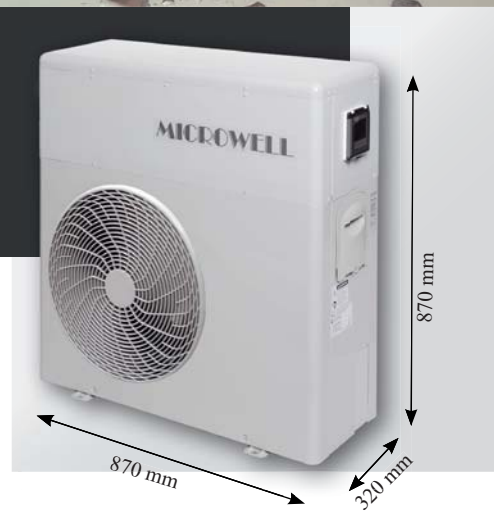

HP 1400 COMPACT O - 1. - 2. - 3. - 4. - 5.

Basic equipment:	Price EXW w/o VAT /EUR/
Heat pump, user's manual	
micro COMPRESSOR + micro ECONOMY + ultra QUIET + anti VIBRATION + anti FREEZE +	1 730
1. Condensate tray defrost:	
S standard: without defrost	0
W with defrost	296
2. Full year modification:	
S standard: without WINTER module (-5°C...+40°C)	0
W with WINTER module (-15°C...+40°C)	325
3. Heat exchanger frost protection:	
S standard: without frost protection	0
W with frost protection	296
4. Control display placement:	
S standard: control display placed on the heat pump	0
W wall installation (out of the heat pump), includes wall plaster box, 30m cable	37
5. WIFI:	
S standard: without WIFI	0
W with WIFI	100
Protection cover:	
<i>Rebate does not apply on this item. This is the actual purchase price.</i>	72
Complete WINTER PACKAGE for better price:	
The package includes: 1. Condensate tray defrost, 2. WINTER module, 3. Heat exchanger frost protection	815



Available as of 1st June



Full range of ACCESSORIES /more on pages 47, 49/



(*) A - air temperature
W - water temperature
RH - measured at 35% - 63% - 80% relative humidity



14.9 kW
60 m³

HP 1500 COMPACT Premium



Cover	COP	Heating output	Cooling output
metal	5.9 - 7.9 (A26 W26)*	12.9 - 17.4 kW (A26 W26)*	11.8 kW (A30 W35)*

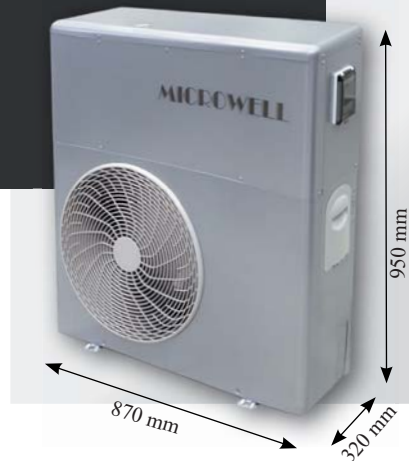

HP 1500 COMPACT P - 1. - 2. - 3. - 4. - 5.

Basic equipment:	Price EXW w/o VAT /EUR/
Heat pump, user's manual	
micro COMPRESSOR + micro ECONOMY + ultra QUIET +	2 340
anti VIBRATION + anti FREEZE +	
1. Condensate tray defrost:	
S standard: without defrost	0
W with defrost	296
2. Full year modification:	
S standard: without WINTER module (-5°C...+40°C)	0
W with WINTER module (-15°C...+40°C)	325
3. Heat exchanger frost protection:	
S standard: without frost protection	0
W with frost protection	296
4. Control display placement:	
S standard: control display placed on the heat pump	0
W wall installation (out of the heat pump), includes wall plaster box, 30m cable	37
5. WIFI:	
S standard: without WIFI	0
W with WIFI	100
Protection cover:	
<i>Rebate does not apply on this item. This is the actual purchase price.</i>	72
Complete WINTER PACKAGE for better price:	
The package includes: 1. Condensate tray defrost, 2. WINTER module, 3. Heat exchanger frost protection	815



S

W



W

Available
as of 1st June



Full range of ACCESSORIES /more on pages 47, 49/



**TESTED
APPROVED**



EXCHANGER
EQUIPPED WITH
**0.7 m² of
TITANIUM**



SWIMMING POOL HEAT PUMPS

14.1 kW
60 m³

HP 1400 SPLIT Omega



Cover	COP	Heating output	Cooling output
metal	5.2 - 7.0 (A ₂₆ W ₂₆)*	12.8 - 17.2 kW (A ₂₆ W ₂₆)*	11.0 kW (A ₃₀ W ₃₅)*



HP 1400 SPLIT O - 1. - 2. - 3. - 4. - 5. - 6. - 7.

Basic equipment:	Price EXW w/o VAT /EUR/
Air unit, user's manual micro COMPRESSOR+ micro ECONOMY+ ultra QUIET+ anti VIBRATION+ anti FREEZE+	1 080
1. Hydro kit (unit with water heat exchanger):	
S standard: without box (installation in technical room)	720
W with box (installation in soil)	900
2. Control display placement:	
S standard: digital display placed on outside unit (air unit)	0
H digital display on remote heat exchanger (heat exchanger box to be installed in interior)	0
W wall installation (out of the heat pump), includes wall plaster box, 30m cable	21
3. WIFI:	
S standard: without WIFI	0
W with WIFI	100
4. Connecting cable length:	
S standard: 10 m	0
M 20 m	46
L 30 m	67
5. Condensate tray defrost:	
S standard: without defrost	0
W with defrost	296
6. Heat exchanger frost protection:	
S standard: without frost protection	0
W with frost protection	296
7. Full year modification:	
S standard: without WINTER module (-5°C...+40°C)	0
W with WINTER module (-15°C...+40°C)	325
Protection cover:	
Rebate does not apply on this item. This is the actual purchase price.	60
Complete WINTER PACKAGE for better price:	
The package includes: 1. Condensate tray defrost, 2. WINTER module, 3. Heat exchanger frost protection	815

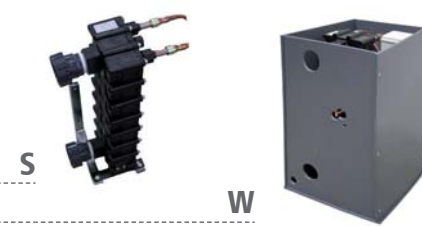

NEW

Available
as of 1st June

Accessories

/more on pages 47 and 49/



(*) A - air temperature
W - water temperature
RH - measured at 35% - 63% - 80% relative humidity



14.9 kW
60 m³

HP 1500 SPLIT Premium



Cover	COP	Heating output	Cooling output
metal	5.9 - 7.9 (A26 W26)*	12.9 - 17.4 kW (A26 W26)*	11.8 kW (A30 W35)*



HP 1500 SPLIT P - 1. - 2. - 3. - 4. - 5. - 6. - 7.

Basic equipment:

Price EXW
w/o VAT /EUR/

Air unit, user's manual

micro COMPRESSOR + micro ECONOMY + ultra QUIET +
anti VIBRATION + anti FREEZE +

1 390

1. Hydro kit (unit with water heat exchanger):

S standard: without box (installation in technical room) 845

W with box (installation in soil) 970

2. Control display placement:

S standard: digital display placed on outside unit (air unit) 0

H digital display on remote heat exchanger (heat exchanger box to be installed in interior) 0

W wall installation (out of the heat pump), includes wall plaster box, 30m cable 21

3. WIFI:

S standard: without WIFI 0

W with WIFI 100

4. Connecting cable length:

S standard: 10 m 0

M 20 m 46

L 30 m 67

5. Condensate tray defrost:

S standard: without defrost 0

W with defrost 296

6. Heat exchanger frost protection:

S standard: without frost protection 0

W with frost protection 296

7. Full year modification:

S standard: without WINTER module (-5°C...+40°C) 0

W with WINTER module (-15°C...+40°C) 325

Protection cover:

Rebate does not apply on this item. This is the actual purchase price. 60

Complete WINTER PACKAGE for better price:

The package includes: **1.** Condensate tray defrost, **2.** WINTER module, **3.** Heat exchanger frost protection 815

Accessories

/more on pages 47 and 49/:



S

W



S

H

W



W



TESTED
APPROVED



EXCHANGER
EQUIPPED WITH
0.7 m² of
TITANIUM



SWIMMING POOL HEAT PUMPS

17 kW
70 m³

HP 1700 COMPACT

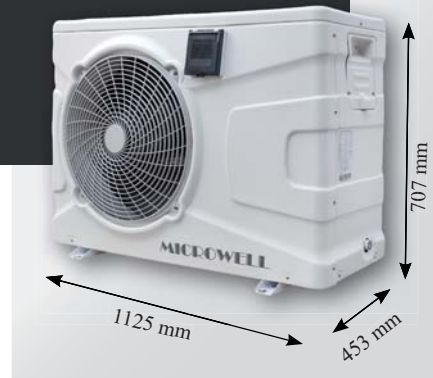

Cover	COP	Heating output	Cooling output
plastic	4.9 (A26 W26, 63% RH)*	14.7 - 19.9 kW (A26 W26)*	13.21 kW (A30 W35)*

HP 1700 COMPACT - 1. - 2. - 3. - 4.

Basic equipment:	Price EXW w/o VAT /EUR/
Heat pump, user's manual	
micro COMPRESSOR + micro ECONOMY + ultra QUIET + anti VIBRATION + anti FREEZE +	2 790
1. Condensate tray defrost:	
S standard: without defrost	0
W with defrost	296
2. Full year modification:	
S standard: without WINTER module (-5°C...+40°C)	0
W with WINTER module (-15°C...+40°C)	325
3. Heat exchanger frost protection:	
S standard: without frost protection	0
W with frost protection	296
4. Control display placement:	
S standard: control display placed on the heat pump	0
W wall installation (out of the heat pump), includes wall plaster box, 30m cable	37
Protection cover:	
<i>Rebate does not apply on this item. This is the actual purchase price.</i>	109
Complete WINTER PACKAGE for better price:	
The package includes: 1. Condensate tray defrost, 2. WINTER module, 3. Heat exchanger frost protection	815



Full range of ACCESSORIES /more on pages 47, 49/

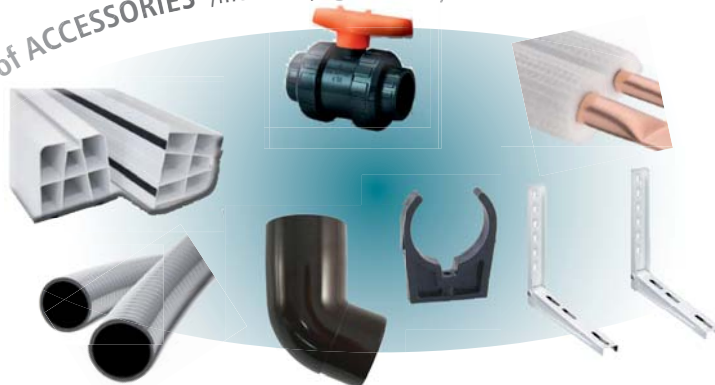

EXCHANGER
EQUIPPED WITH
**0.8 m² of
TITANIUM**

(*) A - air temperature
W - water temperature
RH - measured at 35% - 63% - 80% relative humidity



17 kW
70 m³

HP 1700 SPLIT



Cover	COP	Heating output	Cooling output
plastic	4.9 (A26 W26, 63% RH)*	14.7 - 19.9 kW (A26 W26)*	13.21 kW (A30 W35)*



HP 1700 SPLIT - 1. - 2. - 3. - 4. - 5. - 6.

Basic equipment:	Price EXW w/o VAT /EUR/
Air unit, user's manual	
micro COMPRESSOR + micro ECONOMY + ultra QUIET + anti VIBRATION + anti FREEZE +	1 700
1. Hydro kit (unit with water heat exchanger):	
S standard: without box (installation in technical room)	1 115
W with box (installation in soil)	1 395
2. Control display placement:	
S standard: digital display placed on outside unit (air unit)	0
H digital display on remote heat exchanger (heat exchanger box to be installed in interior)	0
W wall installation (out of the heat pump), includes wall plaster box, 30m cable	21
3. Connecting cable length:	
S standard: 10 m	0
M 20 m	46
4. Condensate tray defrost:	
S standard: without defrost	0
W with defrost	325
5. Heat exchanger frost protection:	
S standard: without frost protection	0
W with frost protection	325
6. Full year modification:	
S standard: without WINTER module (-5°C...+40°C)	0
W with WINTER module (-15°C...+40°C)	550
Protection cover:	
<i>Rebate does not apply on this item. This is the actual purchase price.</i>	109
Complete WINTER PACKAGE for better price:	
The package includes: 1. Condensate tray defrost, 2. WINTER module, 3. Heat exchanger	815

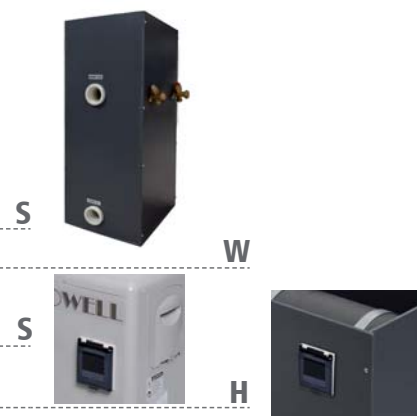

Accessories

/more on pages 47 and 49/



EXCHANGER
EQUIPPED WITH
**0.8 m² of
TITANIUM**



SWIMMING POOL HEAT PUMPS

NEW

23 kW
80 m³

HP 2300 COMPACT Inventor

Cover	COP	Heating output	Cooling output
metal	5.8 - 7.6 (A26 W26)*	20.9 - 27.2 kW (A26 W26)*	20.1 kW (A30 W35)*



HP 2300 COMPACT I - 1. - 2. - 3. - 4. - 5.

Basic equipment:	Price EXW w/o VAT /EUR/
Heat pump, user's manual	
micro COMPRESSOR + micro ECONOMY + ultra QUIET +	3 435
anti VIBRATION + anti FREEZE +	
1. Condensate tray defrost:	
S standard: without defrost	0
W with defrost	325
2. Full year modification:	
S standard: without WINTER module (-5°C...+40°C)	0
W with WINTER module (-15°C...+40°C)	550
3. Heat exchanger frost protection:	
S standard: without frost protection	0
W with frost protection	325
4. Control display placement:	
S standard: control display placed on the heat pump	0
W wall installation (out of the heat pump), includes wall plaster box, 30m cable	37
5. WIFI:	
S standard: without WIFI	0
W with WIFI	100
Protection cover:	
<i>Rebate does not apply on this item. This is the actual purchase price.</i>	139
Complete WINTER PACKAGE for better price:	
The package includes: 1. Condensate tray defrost, 2. WINTER module, 3. Heat exchanger frost protection	968



Full range of ACCESSORIES /more on pages 47, 49/



EXCHANGER
EQUIPPED WITH
**0.95 m² of
TITANIUM**

(*) A - air temperature
W - water temperature
RH - measured at 35% - 63% - 80% relative humidity



NEW

24.4 kW
80 m³

HP 2400 COMPACT Premium

Cover	COP	Heating output	Cooling output
metal	6.5 - 8.5 (A26 W26)*	22.2 - 28.8 kW (A26 W26)*	21.7 kW (A30 W35)*



HP 2400 COMPACT P - 1. - 2. - 3. - 4. - 5.

Basic equipment:	Price EXW w/o VAT /EUR/
Heat pump, user's manual	
micro COMPRESSOR+ micro ECONOMY+ ultra QUIET+ anti VIBRATION+ anti FREEZE+	4 420
1. Condensate tray defrost:	
S standard: without defrost	0
W with defrost	325
2. Full year modification:	
S standard: without WINTER module (-5°C...+40°C)	0
W with WINTER module (-15°C...+40°C)	550
3. Heat exchanger frost protection:	
S standard: without frost protection	0
W with frost protection	325
4. Control display placement:	
S standard: control display placed on the heat pump	0
W wall installation (out of the heat pump), includes wall plaster box, 30m cable	37
5. WIFI:	
S standard: without WIFI	0
W with WIFI	100
Protection cover:	
<i>Rebate does not apply on this item. This is the actual purchase price.</i>	139
Complete WINTER PACKAGE for better price:	
The package includes: 1. Condensate tray defrost, 2. WINTER module, 3. Heat exchanger frost protection	968



Full range of ACCESSORIES /more on pages 47, 49/



EXCHANGER
EQUIPPED WITH
**1.2 m² of
TITANIUM**



SWIMMING POOL HEAT PUMPS

NEW

23 kW
80 m³

HP 2300 SPLIT Inventor



Cover	COP	Heating output	Cooling output
metal	5.8 - 7.6 (A26 W26)*	20.9 - 27.2 kW (A26 W26)*	20.1 kW (A30 W35)*

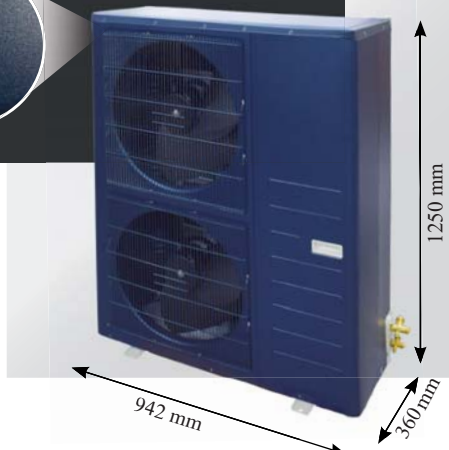

HP 2300 SPLIT I - 1. - 2. - 3. - 4. - 5. - 6. - 7.

Basic equipment:	Price EXW w/o VAT /EUR/
Air unit, user's manual micro COMPRESSOR + micro ECONOMY + ultra QUIET + anti VIBRATION + anti FREEZE +	1 890
1. Hydro kit (unit with water heat exchanger):	
S standard: without box (installation in technical room)	1 545
W with box (installation in soil)	1 735
2. Control display placement:	
S standard: digital display placed on outside unit (air unit)	0
H digital display on remote heat exchanger (heat exchanger box to be installed in interior)	0
W wall installation (out of the heat pump), includes wall plaster box, 30m cable	21
3. WIFI:	
S standard: without WIFI	0
W with WIFI	100
4. Connecting cable length:	
S standard: 10 m	0
M 20 m	46
5. Condensate tray defrost:	
S standard: without defrost	0
W with defrost	325
6. Heat exchanger frost protection:	
S standard: without frost protection	0
W with frost protection	325
7. Full year modification:	
S standard: without WINTER module (-5°C...+40°C)	0
W with WINTER module (-15°C...+40°C)	550
Protection cover:	
<i>Rebate does not apply on this item. This is the actual purchase price.</i>	109



Complete WINTER PACKAGE for better price:	
The package includes: 1. Condensate tray defrost, 2. WINTER module, 3. Heat exchanger frost protection	968



EXCHANGER EQUIPPED WITH **0.95 m² of TITANIUM**

(*) A - air temperature
W - water temperature
RH - measured at 35% - 63% - 80% relative humidity



NEW

24.4 kW
80 m³

HP 2400 SPLIT Premium

Cover	COP	Heating output	Cooling output
metal	6.5 - 8.5 (A26 W26)*	22.2 - 28.8 kW (A26 W26)*	21.7 kW (A30 W35)*

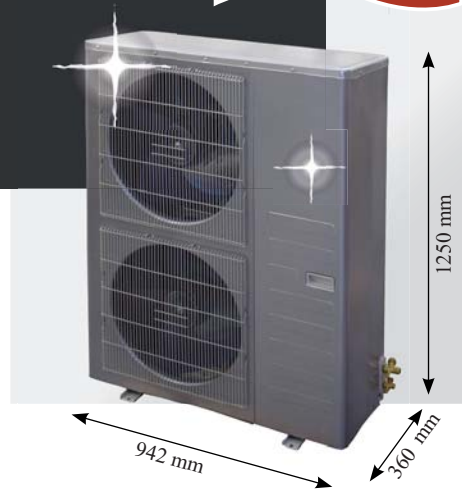

HP 2400 SPLIT P - 1. - 2. - 3. - 4. - 5. - 6. - 7.

Basic equipment:	Price EXW w/o VAT /EUR/
Air unit, user's manual micro COMPRESSOR + micro ECONOMY + ultra QUIET + anti VIBRATION + anti FREEZE +	2 400
1. Hydro kit (unit with water heat exchanger):	
S standard: without box (installation in technical room)	2 020
W with box (installation in soil)	2 215
2. Control display placement:	
S standard: digital display placed on outside unit (air unit)	0
H digital display on remote heat exchanger (heat exchanger box to be installed in interior)	0
W wall installation (out of the heat pump), includes wall plaster box, 30m cable	21
3. WIFI:	
S standard: without WIFI	0
W with WIFI	100
4. Connecting cable length:	
S standard: 10 m	0
M 20 m	46
5. Condensate tray defrost:	
S standard: without defrost	0
W with defrost	325
6. Heat exchanger frost protection:	
S standard: without frost protection	0
W with frost protection	325
7. Full year modification:	
S standard: without WINTER module (-5°C...+40°C)	0
W with WINTER module (-15°C...+40°C)	550
Protection cover:	
<i>Rebate does not apply on this item. This is the actual purchase price.</i>	109
Complete WINTER PACKAGE for better price:	
The package includes: 1. Condensate tray defrost, 2. WINTER module, 3. Heat exchanger frost protection	968



S

W

S

H

W



W



Available as of 1st June



Accessories

/more on pages 47 and 49/



EXCHANGER EQUIPPED WITH **1.2 m² of TITANIUM**



SWIMMING POOL HEAT PUMPS

NEW

28.4 kW
120 m³

HP 2800 COMPACT Inventor

Cover	COP	Heating output	Cooling output
metal	5.8 - 7.6 (A26 W26)*	25.8 - 33.5 kW (A26 W26)*	25 kW (A30 W35)*



HP 2800 COMPACT I - 1. - 2. - 3. - 4. - 5.

Basic equipment:

Price EXW
w/o VAT /EUR/

Heat pump, user's manual

micro COMPRESSOR+ micro ECONOMY+ ultra QUIET+
anti VIBRATION+ anti FREEZE+

3 880

1. Condensate tray defrost:

S standard: without defrost	0
W with defrost	325

2. Full year modification:

S standard: without WINTER module (-5°C...+40°C)	0
W with WINTER module (-15°C...+40°C)	550

3. Heat exchanger frost protection:

S standard: without frost protection	0
W with frost protection	325

4. Control display placement:

S standard: control display placed on the heat pump	0
W wall installation (out of the heat pump), includes wall plaster box, 30m cable	37

5. WIFI:

S standard: without WIFI	0
W with WIFI	100

Protection cover:

<i>Rebate does not apply on this item. This is the actual purchase price.</i>	139
---	-----

Complete WINTER PACKAGE for better price:

The package includes: 1. Condensate tray defrost, 2. WINTER module, 3. Heat exchanger frost protection	968
---	-----



Full range of ACCESSORIES /more on pages 47, 49/

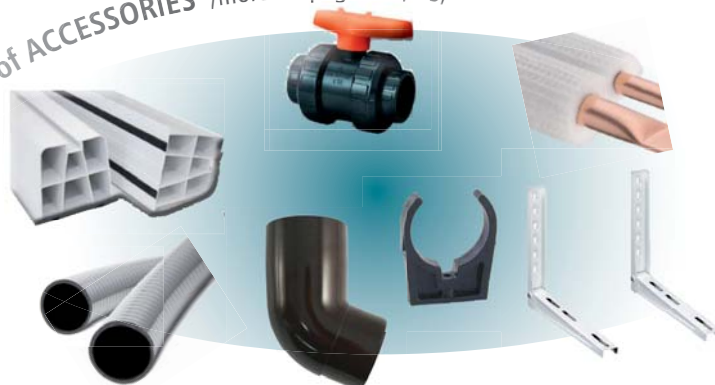

EXCHANGER
EQUIPPED WITH
**1.1 m² of
TITANIUM**



NEW

30.1 kW
120 m³

HP 3000 COMPACT Premium

Cover	COP	Heating output	Cooling output
metal	6.5- 8.5 (A26 W26)*	27.4 - 35.5 kW (A26 W26)*	26.8 kW (A30 W35)*

HP 3000 COMPACT P - 1. - 2. - 3. - 4. - 5.



Basic equipment:

Price EXW

w/o VAT /EUR/

Heat pump, user's manual

micro COMPRESSOR +

micro ECONOMY +

ultra QUIET +

4 890

anti VIBRATION +

anti FREEZE +

1. Condensate tray defrost:

S standard: without defrost 0

W with defrost 325

2. Full year modification:

S standard: without WINTER module (-5°C...+40°C) 0

W with WINTER module (-15°C...+40°C) 550

3. Heat exchanger frost protection:

S standard: without frost protection 0

W with frost protection 325

4. Control display placement:

S standard: control display placed on the heat pump 0

W wall installation (out of the heat pump), includes wall plaster box, 30m cable 37

5. WIFI:

S standard: without WIFI 0

W with WIFI 100

Protection cover:

Rebate does not apply on this item. This is the actual purchase price. 139

Complete WINTER PACKAGE for better price:

The package includes: 1. Condensate tray defrost, 2. WINTER module, 3. Heat exchanger frost protection 968



Full range of ACCESSORIES /more on pages 47, 49/

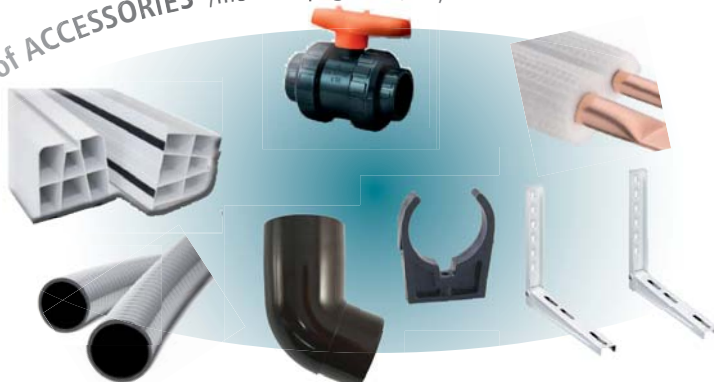

EXCHANGER
EQUIPPED WITH
**1.4 m² of
TITANIUM**



SWIMMING POOL HEAT PUMPS

28.4 kW
120 m³

HP 2800 SPLIT Inventor

Cover	COP	Heating output	Cooling output
metal	5.8 - 7.6 (A26 W26)*	25.8 - 33.5 kW (A26 W26)*	25 kW (A30 W35)*

NEW



HP 2800 SPLIT I - 1. - 2. - 3. - 4. - 5. - 6. - 7.

Basic equipment:	Price EXW w/o VAT /EUR/
Air unit, user's manual micro COMPRESSOR + micro ECONOMY + ultra QUIET + anti VIBRATION + anti FREEZE +	2 140
1. Hydro kit (unit with water heat exchanger):	
S standard: without box (installation in technical room)	1 740
W with box (installation in soil)	2 040
2. Control display placement:	
S standard: digital display placed on outside unit (air unit)	0
H digital display on remote heat exchanger (heat exchanger box to be installed in interior)	0
W wall installation (out of the heat pump), includes wall plaster box, 30m cable	21
3. WIFI:	
S standard: without WIFI	0
W with WIFI	100
4. Connecting cable length:	
S standard: 10 m	0
M 20 m	46
5. Condensate tray defrost:	
S standard: without defrost	0
W with defrost	325
6. Heat exchanger frost protection:	
S standard: without frost protection	0
W with frost protection	325
7. Full year modification:	
S standard: without WINTER module (-5°C...+40°C)	0
W with WINTER module (-15°C...+40°C)	550
Protection cover:	
Rebate does not apply on this item. This is the actual purchase price.	109
Complete WINTER PACKAGE for better price:	
The package includes: 1. Condensate tray defrost, 2. WINTER module, 3. Heat exchanger frost protection	968



Available
as of 1st June



Accessories

/more on pages 47 and 49/



EXCHANGER
EQUIPPED WITH
**1.1 m² of
TITANIUM**

(*) A - air temperature
W - water temperature
RH - measured at 35% - 63% - 80% relative humidity



NEW

30.1 kW
120 m³

HP 3000 SPLIT Premium

Cover	COP	Heating output	Cooling output
metal	6.5- 8.5 (A26 W26)*	27.4 - 35.5 kW (A26 W26)*	26.8 kW (A30 W35)*

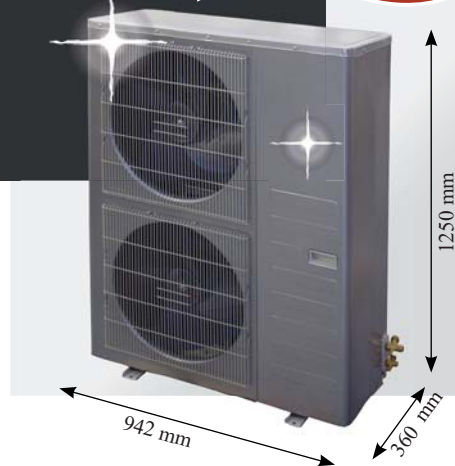

HP 3000 SPLIT P - 1. - 2. - 3. - 4. - 5. - 6. - 7.

Basic equipment:	Price EXW w/o VAT /EUR/
Air unit, user's manual micro COMPRESSOR + micro ECONOMY + ultra QUIET + anti VIBRATION + anti FREEZE +	2 750
1. Hydro kit (unit with water heat exchanger):	
S standard: without box (installation in technical room)	2 140
W with box (installation in soil)	2 400
2. Control display placement:	
S standard: digital display placed on outside unit (air unit)	0
H digital display on remote heat exchanger (heat exchanger box to be installed in interior)	0
W wall installation (out of the heat pump), includes wall plaster box, 30m cable	21
3. WIFI:	
S standard: without WIFI	0
W with WIFI	100
4. Connecting cable length:	
S standard: 10 m	0
M 20 m	46
5. Condensate tray defrost:	
S standard: without defrost	0
W with defrost	325
6. Heat exchanger frost protection:	
S standard: without frost protection	0
W with frost protection	325
7. Full year modification:	
S standard: without WINTER module (-5°C...+40°C)	0
W with WINTER module (-15°C...+40°C)	550
Protection cover:	
Rebate does not apply on this item. This is the actual purchase price.	109
Complete WINTER PACKAGE for better price:	
The package includes: 1. Condensate tray defrost, 2. WINTER module, 3. Heat exchanger frost protection	968



S

W

S

H

W



W



Available as of 1st June



Accessories

/more on pages 47 and 49/



EXCHANGER EQUIPPED WITH **1.4 m² of TITANIUM**





Microwell offers additional assortment consisting of wide selection of installation material and equipment.



Accessories



Qmax-TESTER



Cover	Measurement accuracy
metal	± 5%

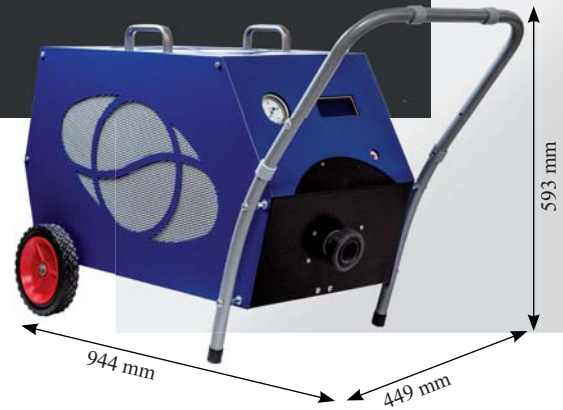

Carry-on measurement device designed to provide measurement and optimization of heat pump's performance and efficiency

Price EXW
w/o VAT /EUR/

Basic equipment:

- Carry on measurement device with inductive flow meter KROHNE Optiflux 2050 with connection DN50
- A pair of mobile WIKA Pt100 resistance thermometers
- Measurement device



1. Qmax-TESTER

measures: water temperature inlet & outlet, true heating or cooling output, heat pump power consumption, water flow
counts: Coefficient of performance /COP/, Energy efficiency ratio /EER/

2 890

2. Heat pump's OPTIMIZATION

executed by a Microwell trained technician

99



General rebate does not apply on above stated prices.
Stated prices are final.

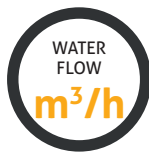

IMMEDIATE TESTING
OF A HEAT PUMP



ACCESSORIES

FLOAT SWITCHES FOR EQUALIZING TANKS

Float switches for equalizing tanks	Price EXW w/o VAT /EUR/
1. NIVOCONT - conductive level switch	
A KSN-201 - probe from stainless steel	33.60
B KRK-512-5 - relay	47.30
2. NIVOFLOAT - plastic level switch	
A NLP-110 - plastic level float switch (PVC cable 10m)	31.80
3. NIVOPOINT - multiple switching point magnetic level switch:	
A MRA-210-3 - multiple switching point level switch with wetted parts from stainless steel (1" thread, 2 switching points, probe tube 1m)	204.00

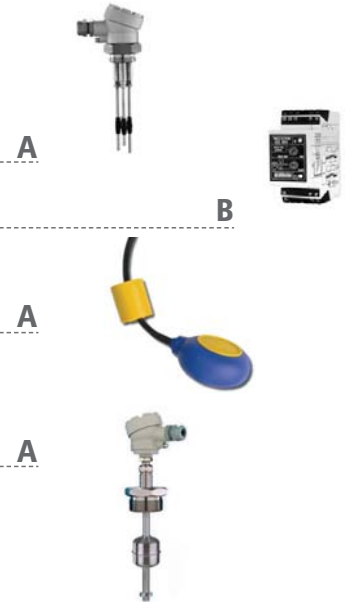

HUMIDITY AND TEMPERATURE METER in 1

Device for indoor humidity and temperature measuring	Price EXW w/o VAT /EUR/
1. HOME - MOMERT 1756 (home use)	
Humidity 10% to 99% Air temperature -10°C ~ +60°C Selection °C/°F Wall installation / flipping holder Well readable display Measurement accuracy ± 5% Battery 1x 1.5V	11.00
2. PROFESSIONAL- GFTH 95 (professional application)	
Humidity measurement accuracy: ± 1,5% 1 line LCD Battery included 1x 9V, typ IEC 6F22 Body: ABS	153.00

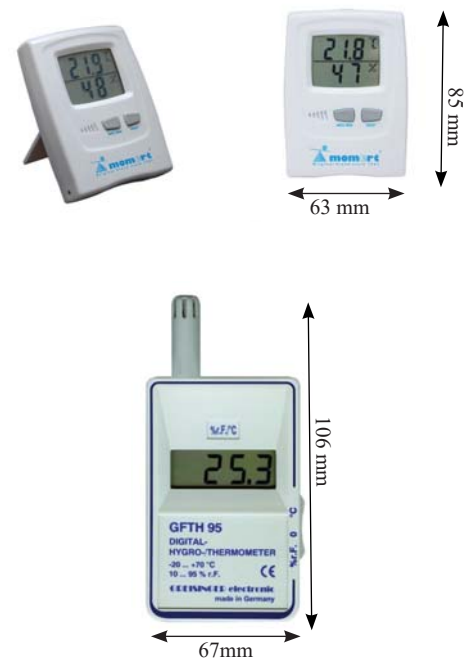

/Change in price and offered products reserved./



HUMIDITY VISUALIZATION

microLIGHT +



Price EXW
w/o VAT /EUR/

1. microLIGHT+ INFINITY

Operational temperature range: 0°C ... +60°C.
Compatibillity: All DRY range

A microLIGHT+ INFINITY, length 1 m	183.00
B microLIGHT+ INFINITY, length 3 m	213.00
C microLIGHT+ INFINITY, length 5 m	228.00

2. microLIGHT+ LAMP

A freestanding table lamp.
MicroLIGHT+ LAMP measures and automatically reflects current relative humidity, changing the colour gradient between blue, green and red colour.

A microLIGHT+ LAMP	105.00
---------------------------	---------------

3. microSTEAM+

Operational temperature range: 0°C ... +120°C

A microSTEAM+, length 1 m	229.00
B microSTEAM+, length 2 m	253.00

/Change in Lamp model reserved./

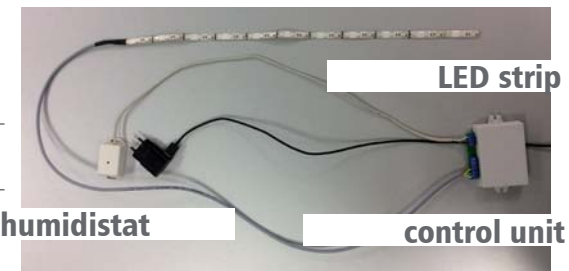

High humidity
60-100% RH

Ideal humidity
40-60% RH

Low humidity
0-40% RH





FLOOR GRILLS

/Actual price to be quoted based on an individual enquiry./

Price EXW
w/o VAT /EUR/

1. Basic structure

A Symmetrical ASS	from 154.00
B Asymmetrical ASU	from 160.00
C Asymmetrical removable ASR	from 207.00

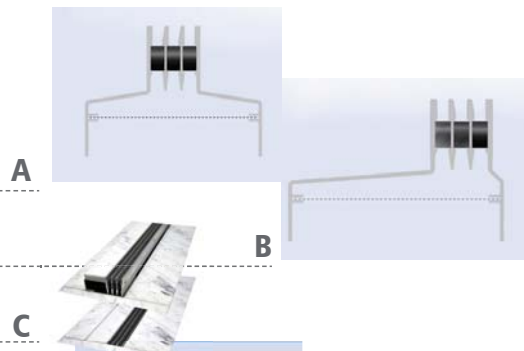

2. Fixation

A Mounting rail AS-BF	from 34.50
B Substructure channel AS-UBK	from 252.00

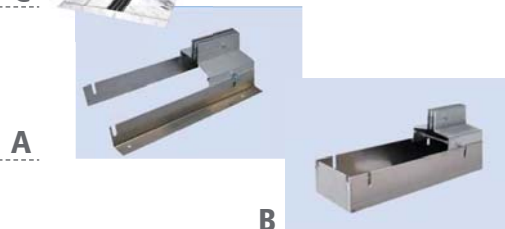

3. Accessories

A Comer AS-GS	from 69.90
B Diffuser AS-DLV	from 11.40
C Construction works protection cover AS-AP	from 6.50
D Cut out for substructure channel AS-UBK-A	from 13.00
E Substructure channel socket AS-UBK-ZSR	from 28.40
F Side cut out with socket for mounting rail or substructure channel AS-UBK-ZS	from 28.40
G End cover AS-END	from 16.80
H Condensate drain for substructure channel AS-UBK-AS	from 47.00

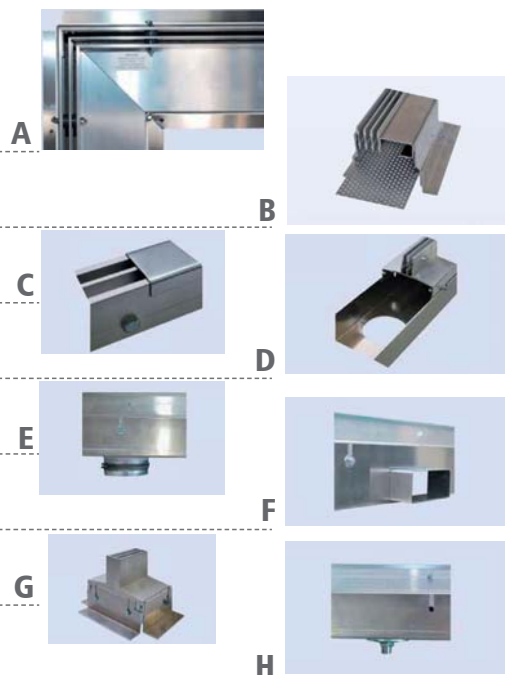

/Price change reserved./





INSTALLATION MATERIAL

for SWIMMING POOL DEHUMIDIFIERS installation Price EXW w/o VAT /EUR/

1. Pumps and accessories	
A Pump SI 82 – condensing, with tank 2l, 500l/h, max. 5m	65.00
B Condensate hose with metal spiral 18/12mm – 1 standard meter	4.50
2. Cleaning and disinfection appliances	
A Easy Care spray – evaporator cleaner and disinfection	14.50
3. In-wall condensate siphons	
A In-wall condensate siphon HL 138	34.00

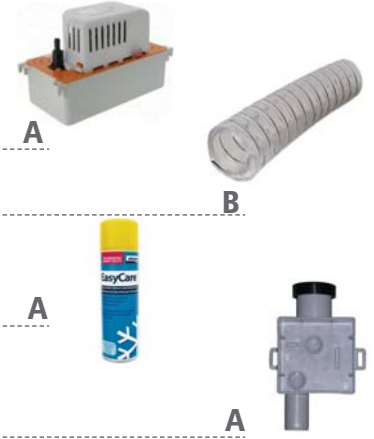

for SWIMMING POOL HEAT PUMP installation Price EXW w/o VAT /EUR/

1. Copper pipes	
A for HP900 SPLIT Insulated double copper pipes DUO 6+12 (1/4"+1/2" x 0,8) - 20m package	75.00
B for HP 1200 SPLIT Insulated double copper pipes DUO 10+16 (3/8" x 5/8") - 20m package	116.40
C for HP 2000/2600 SPLIT Insulated copper pipes d10 - 50m package + insulated copper pipes d18 - 50m package	352.50
2. Insulation tape	
A A self-adhesive insulation tape K-flex white – 10m package	9.80
3. Consoles and base blocks	
A Console White - 700	32.00
B Base installation block 450 – white, carrying capacity 200kg, 2pcs	5.68
C Antivibration silentblocks, 4pcs	15.50
4. Cleaning and disinfection appliances	
A Easy Care spray – evaporator cleaner and disinfection	14.50

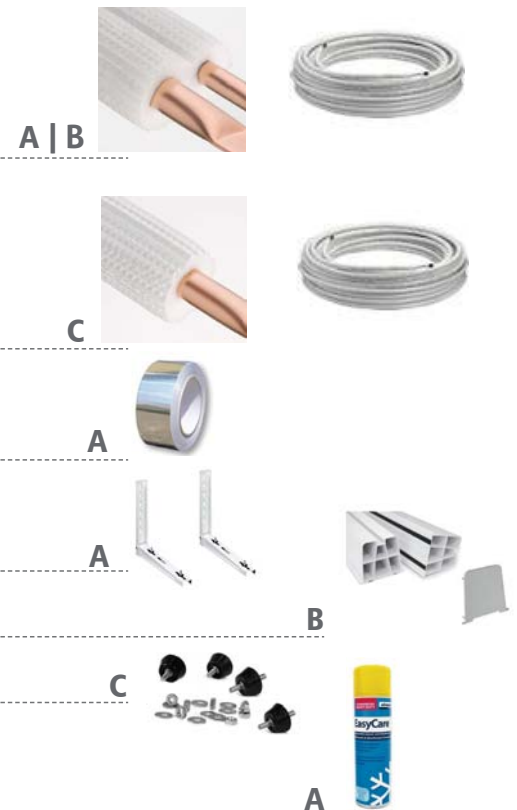

/Price change reserved./





	Price EXW w/o VAT /EUR/
1. Vacuum pump	
A Vacuum pump Rothenberger ROAIRVAC 6,0 - 170l/min	318.00
2. Charging and testing hoses Refco	
A Premium with closure valve, length 90cm	46.62
B Premium with closure valve, length 150cm	56.09
3. Manifold valve Refco	
A for refrigerant R410, R32	90.04
B for refrigerant R22, R407, R410	80.81
4. Eccentric flare tool	
A Eccentric flare tool Rothenberger, with 1" flare matrix, 222402	145.76
B Eccentric flare tool REFCO, with 1" flare matrix in small suitcase, RF888Z	117.47
C Eccentric flare tool REFCO, flare matrix and cutter in small suitcase, RF275FS	88.32
D Flare tool Rothenberger with expanding – 1" packet	52.65
5. Expanders	
A Expander Rothenberger 3/8, 1/2, 5/8, 3/4, 22, 28 - 1" packet, 12320	329.40
6. Cutters	
A Cutter Rothenberger MINIMAX 3 - 28mm, 70015	20.30
B Cutter Rothenberger TC 35, 6- 35mm, 70027	24.11
7. Tube benders	
A Tube bender Rothenberger TBM 3/8, 1/2, 5/8, 3/4, 7/8, 23022X	218.95
8. Charging scales	
A Charging scale Rothenberger to 120kg - accuracy 2g, 173004	270.60
B Charging scales TST	167.30



A



A | B

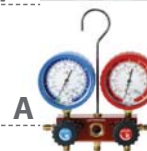

A



B



A



B



A



B



A



A



B



A



A

/Price and model change reserved./



WATER CONNECTION PACKET

for HEAT PUMP CONNECTION to pool water circuit

Price EXW
w/o VAT /EUR/

Price for the whole set:

110.00

1 Pressure hose d50, length 10m



1

2 PVC tube d50, length 0.8m

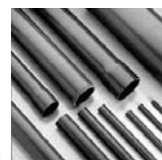

2

3 Tube holder, open, d50, 8pcs



3

4 Hose nut / Swivel for glue d50 x external thread 1 1/2", 2pcs



4

5 PVC tube knee 90° for glue, 8pcs



5

6 Swivel with valve for glue d50, 3pcs



6

7 PVC "T" piece 90° for glue d50, 2pcs



7

8 Glue Tangit PVC-U, 250g



8

9 Cleaner Tangit 125 ml



9

10 Sealing fibre Tangit Uni-Lock, 1 package



10

11 Teflon tape 12 mm/12 m



11

12 Screw fasteners with screws, 8pcs



12

13 Cardboard box, 800x600x600 mm



13

/Price change reserved./



SMART
PURCHASE
Buy the whole set.



DRY TECHNICAL DATA

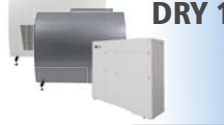

Series	Model	Pool surface m ²	Extraction rate l/24hrs /60% RH, 30°C/	Extraction rate l/24hrs /80% RH, 30°C/	Air flow m ³ /h	Noise level (at 1 m dist.) dB (A)	Power consump. W	Heating output W	Dimensions netto (W x H x D) mm	Weight netto kg
DRY 300	PLASTIK	30	36	48	550	42	700	1900	780 x 660 x 255	40
	SILVER								780 x 642 x 300	50
	METAL								780 x 642 x 300	50
	TTW								780 x 660 x 255	40
	DUCT									
DRY 400	PLASTIK	45	48	58	600	42	700	1900	780 x 660 x 255	40
	SILVER								780 x 642 x 300	50
	METAL								780 x 642 x 300	50
	TTW								780 x 660 x 255	40
	DUCT									
DRY 500	PLASTIK	60	66	101	800	44	1000	3500	1245 x 660 x 255	60
	SILVER								1245 x 642 x 300	77
	METAL								1245 x 642 x 300	77
	TTW								1245 x 660 x 255	60
	DUCT								50	52
DRY 800	METAL	90	90	136	1100	46	1600	5100	1250 x 950 x 310	100
	TTW					46	1600	5100	1247 x 950 x 300	100
	DUCT	80	88	135	1100/ 170Pa	58	1700	5100	1247 x 950 x 300	102
DRY 1200	METAL	120	120	181	1200	46	2150	5250	1250 x 950 x 310	104
	TTW					46	2150	5250	1247 x 950 x 300	103
	DUCT	110	112	170	1200/ 145Pa	60	2250	5250	1247 x 950 x 300	103
DRY SIREN	SOLO	60	67	104	1000	35	1000	4500	Ø 1205 x 278	53+20
	DUE	120	134	208	2000	35	2300	8750	2x Ø 1205 x 278	2x53+20



Product of the year
2005
DRY 500 METAL



Product of the year
2013
DRY 500 METAL



Product of the year 2014
HP 1200 COMPACT Premium



Recognition prize 2014
DRY 500 DUCT



The BEST EXHIBIT award
2017
DRY SIREN



Recognition prize 2017
DRY SIREN



Series	Model	Pool capacity (cover/ no cover)	Heating capacity (A25/W10, RH35%)	Cooling capacity (A30/W35)	(A26/W26, RH63%)			Water flow m³/h kPa	Power supply V AC/ Ph	Titanium surface Titanium Gr2 ASTM B338	Acoustic pressure level (1m/2m/ 4m/8m)	Dimensions netto (W x H x D) condensing unit+water unit with box (without box)	Weight netto condensing unit+water unit with box (without box)
					Heat capacity kW	Power cons. kW	COP						
HP 1000	COMPACT Omega	40 / 30	9.1	7.6	10.7	1.88	5.7	4-6	5-15	0.43 m²	54/48/42/36	870x870x320	67
	SPLIT Omega											870x655x320 + 345x590x415 (450x590x220)	59+21.5(10.5)
HP 1100	COMPACT Premium	60 / 40	10	8.2	11.3	1.74	6.5	4-6	1-5	0.60 m²	55/49/43/37	870x950x320	67
	SPLIT Premium											870x655x320 + 750x370x430 (650x370x400)	59+28(12)
HP 1400	COMPACT Omega	60 / 40	12.1	11.0	14.1	2.47	5.7	4-6	5-15	0.48 m²	55/49/43/37	870x870x320	69
	SPLIT Omega											870x655x320 + 345x590x415 (450x590x220)	60+21.5(10.5)
HP 1500	COMPACT Premium	70 / 50	13	11.8	14.9	2.29	6.5	4-6	1-5	0.7 m²	56/50/43/39	870x950x320	69
	SPLIT Premium											870x655x320 + 750x370x430 (650x370x400)	60+28(12)
HP 1700	COMPACT	70 / 50	14.7	13.21	17.01	3.47	4.9	6-8	5-15	0.80 m²	56/50/43/39	1125x707x453	96
	SPLIT											1125x707x453 + 750x370x430 (650x370x400)	86+28(12)
HP 2300	COMPACT Inventor	80 / 60	20	20.1	23	3.59	6.4	8-10	5-15	0.95 m²	56/50/44/38	942x1550x360	118
	SPLIT Inventor											942x1250x360 + 1045x370x430 (970x275x340)	102+40.1(17.7)
HP 2400	COMPACT Premium	120 / 80	21.2	21.7	24.4	3.51	6.9	8-10	1-5	1.2 m²	56/50/44/38	942x1550x360	118
	SPLIT Premium											942x1250x360 + 1045x370x430 (970x275x340)	102+40.1(17.7)
HP 2800	COMPACT Inventor	120 / 80	26	25.0	28.4	4.44	6.4	8-12	5-15	1.1 m²	56/50/44/38	942x1550x360	120
	SPLIT Inventor											942x1250x360 + 1045x370x430 (970x275x340)	102+40.1(17.7)
HP 3000	COMPACT Premium	120 / 80	27.7	26.8	30.1	4.34	6.9	8-12	1-5	1.4 m²	56/50/44/38	942x1550x360	120
	SPLIT Premium											942x1250x360 + 1045x370x430 (970x275x340)	102+40.1(17.7)

Related to all models:

Operating temperature: **-15 ... +40°C**
 Water circuit connection (mm /inch/thread): **Ø50 / 6/4" / internal**
 Refrigerant: **R410A**

- Included:**
- micro **ECONOMY** +
 - anti **FREEZE** +
 - anti **VIBRATION** +
 - ultra **QUIET** +

New:



Compatible:





Manufacturer reserves the right to change the technical and visual parameters without notice.

MICROWELL, spol. s r.o.
SNP 2018/42
927 00 Šal'a, SLOVAKIA
p (+421) 31/702 0540
m (+421) 911/413 990
f (+421) 31/702 0542
e export@microwell.sk

Branch office PRAHA

Šífařská 1/3

147 00 Praha 4, CZ

p (+420) 244 400 169

m (+420) 773 621 599

e paha@microwell.cz

www.microwell.cz

Branch office BRNO

Bohunická 81

619 00 Brno, CZ

p (+420) 549 257 241

m (+420) 608 746 333

e klimatizace@microwell.cz

www.microwell.cz

Branch office OSTRAVA

Slévárenská 411/12

709 00 Ostrava, CZ

p (+420) 596 638 227

m (+420) 608 855 364

e microwell@microwell.cz

www.microwell.cz

Branch office BUDAPEST

Rákoczi utca 42

2092 Budakeszi, HU

p (+36) 23 399 404

m (+36) 30 875 58 51

e microwell@microwell.hu

www.microwell.hu

www.microwell.eu